

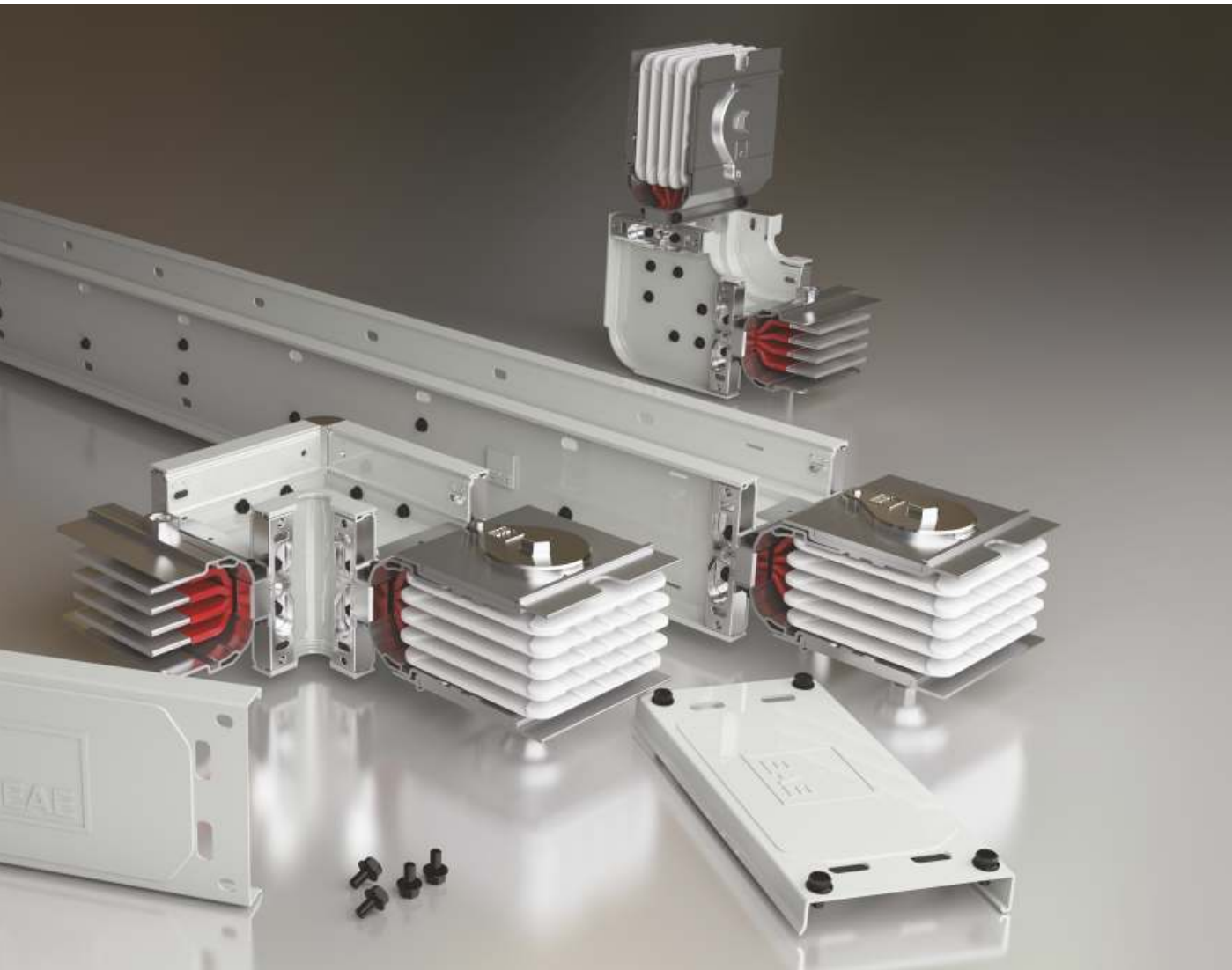

E-LINEKX

Busbar Systems 400...6300A



E-LINEKX



CONTENTS

►► E-LINE KX

Introduction	2-3
Distribution & Horizontal Applications	4
Riser & Vertical Applications	5
Technical Characteristics	6-9
Order Code System	10
Straight Lengths	11
Elbows	12-15
Standard Components	16
Expansions	17-18
End Closer	19
Panel Connections	20-24
Transformer Connections & Flexible	25-29
Tap-off Boxes	30-35
Vertical & Horizontal Support Applications	36-37
Feeder Boxes	38-39
Fixing Elements	40-48
Joint Structure	49
Measuring a Special Length	50
Inserting "Make-up Section"	51
CE Conformity Certificate	52
Certificates	53
Product Specification	54

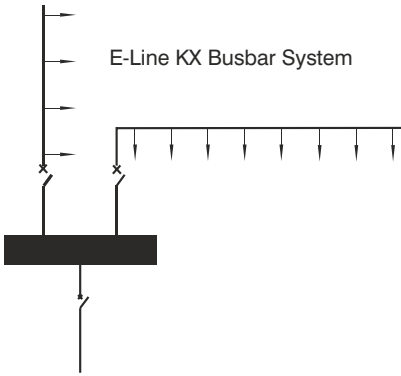
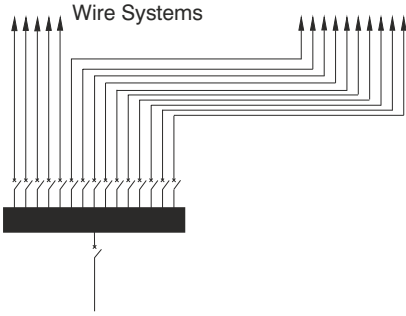

Transportation and distribution of electricity especially at high ampere ratings used to be provided by paralleling a number of large sized cables. In order to support these cables in the buildings, there were used a lot of cable trays, cable ladders, under-floor cable channels, etc. Applications of cables, such as, fixing to cable channels, branching, connecting, calculating distances between cables for heat dissipation, adjusting difference lengths, etc. need special expert workers, more time, more effort, which means more money. Even after all above difficulties and expense, the result is not efficient enough. For example, there is no flexibility in this solution.

In order to eliminate all above disadvantages, modern **BUSBAR SYSTEMS** are developed. **EAE** manufactures **E-LINE** busbar systems from 25A up to 6.300A in order to convert above disadvantages to advantages. High technological, modular structured **E-LINE** busbar systems allow users to get safe energy how much and where ever they need by tap off boxes, easy and efficient planning, short installation time, better heat dissipation, automatic length adjustments, re-design / re-using capability, better electrical characteristics, etc. **E-LINE** busbar systems are designed and certified as per IEC 61439-6 standard.

Standard Prefabricated Structure

E-Line KX busbar system can be adapted to any kind of building structure using. Space-saving prefabricated components. All necessary components and fitting elements are manufactured items.

** Special components can be manufactured in one week on request.*

Rapid and Efficient Installation

It has been important to keep abreast with the rapidly improving building technologies in civil engineering, the installation time we have lowered by reducing the number of bolts on the joint points of the busbar.

Flexible Power Supply

Tap-off points at short intervals make electrical power available in all locations; the power supply can be adapted to different production processes simply by relocating the tap-off unit.

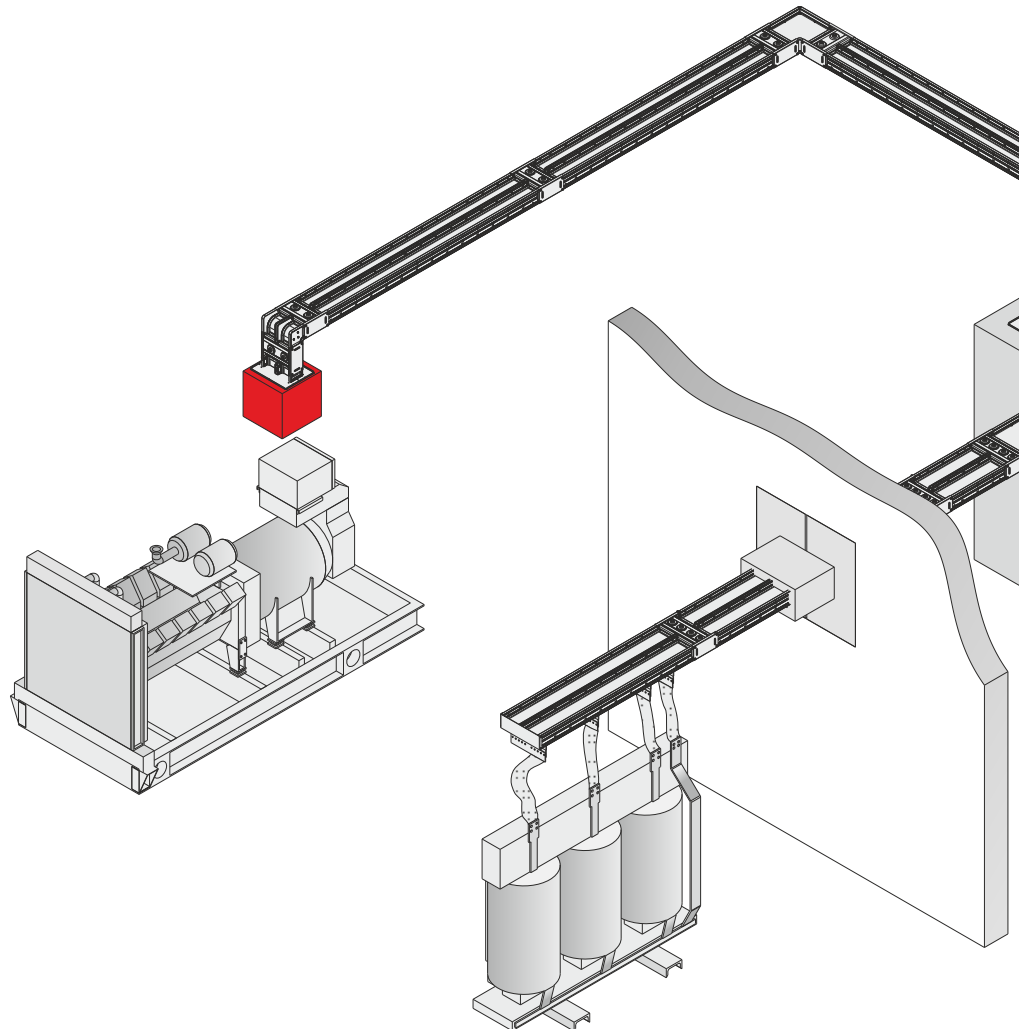

►► Technical Features

Hybrid Insulation

The perfect design for high current busbar systems is the "compact structure" where tin plated and insulated with B class polyester film and epoxy coated on conductors are tightly placed into the extruded aluminium housing (Figure 1).

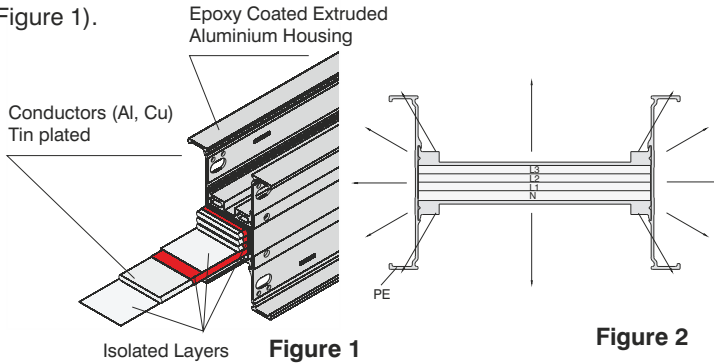

Figure 1

Figure 2

Heat Transfer

"In compact structure" there is no empty space filled with air and heat is easily transferred to the environment by the housing that works like a heat-shink (Figure 2).

Minimum Voltage Drop

In E-Line KX, inductive reactance is very low due to closely placed conductors. The voltage drop comparison of compact and ventilated busbar that have same cross sectional area prove the importance of the compact structure.

High Short-Circuit Endurance

As there are no support points in "compact structure", momentum levers are not formed (Figure 1). This feature ensures high short-circuit endurance (Figure 5).

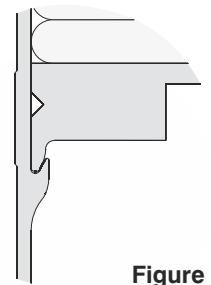

Figure 5

One Bolt Joint Ensures Safety and Easy Installation

E-Line KX Busbars are installed by tightening the "one bolt joint". Belleville spring washers on both ends of the bolt retains the original contact pressure, ensuring a more secure, reliable and maintenance - free joint.

E-Line KX Busbar Systems are easily installed (Figures 3-4).

Easy and Safe Installation:

Due to alignment piece on the joint point, block joint element and busbar tray are aligned. This makes installation easier and correct on the right axes. (Figure 6).

** The bolt is tightened to 83 Nm (60 lbft) using the torque spanner.*

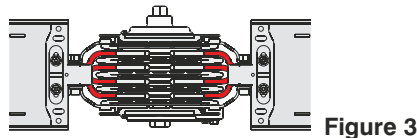

Figure 3

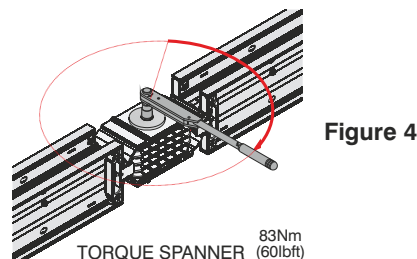
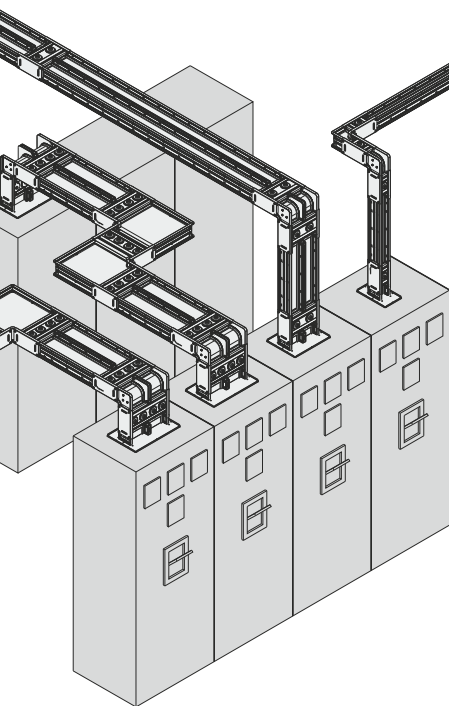

Figure 4

TORQUE SPANNER 83Nm (60lbft)



Figure 6



While designing an electrical distribution system with E-Line KX a few approximate details will be necessary.

- Location, number, type and approximate ratings of loads,
- Transformer rates and short-circuit capacities, Utilization factor=a,
- System coordination with other distribution system (heat, water, etc),
- Determining the route of E-Line KX on layout, If necessary, coordination of E-Line KX Busbar with E-Line KO-II runs,
- Deciding on suitable hanger types.

Utilization Factor (a)

Utilization factor (a) depends on the type and number of loads.

It is usually around 0.7 or lower. The utilization factor of a line that supplies electricity to motors and lighting systems is usually lower than 0.6.

It is as low as 0.30 in weld shops of car factories, it can be 1 in lines where only one big load is supplied.

Voltage Drop

For practical voltage drop calculation, necessary values, formula and easy calculation methods are given on the technical characteristics table on pages 6-9.

Rated Current

The current is calculated using the following equation:

$$I_B = \frac{Pa}{\sqrt{3} \cdot U \cdot \cos j}$$

I_B = Operation current (A)

P = Installed load (W)

a = Utilization factor

U = Supply voltage (V)

- Busbar current rating is chosen as equal to or higher than the calculated I_B current.
- After the voltage drop calculation if the chosen current rate is not convenient, a higher rating is chosen.

Short-Circuit

Tested short-circuit capacities are given on technical characteristics table on pages 6-9.

Busbar Installation Plan

Our distributor's project & design departments will help you for preparing the installation plans on request.

Components List		
Item	Components	Quantity
1	KXA 20504 - STD Busbar (20 x 3m.)	60 m.
2	KXA 20504 - D Downwards Elbow	2 pcs.
3	KXA 20504 - R Right Elbow	1 pc.
4	KXA 20504 - U Upwards Elbow	1 pc.
5	KXA 20504 - L Left Elbow	1 pc.
6	KXA 20504 - P11 Panel Connection	1 pc.
7	KXA 20504 - S10 End Closer	1 pc.
8	KXA 20504 - X95 Special Straight Length	1 pc.
8	KXA 20504 - X120 Special Straight Length	1 pc.
9	KXA 20504 - X122 Special Straight Length	1 pc.
10	KXA 20504 - X200 Special Straight Length	1 pc.
11	KXA 20504 - X174 Special Straight Length	1 pc.
12	KXP 1650 Tap-off Box	8 pcs.
13	KXB 2550 Tap-off Box	6 pcs.

Company : Demir Makine
Project : II.OSB Tesisleri
Project No : 1128

Prepared by Name : Abdullah ELDELEKLİ
Date : 02 / 01 / 2009
Signature:

As each building's structure is different than the other for vertical applications of **E-Line KX** special projects has to be designed.

The details on this page briefly explain the necessary information for drawing a vertical application project.

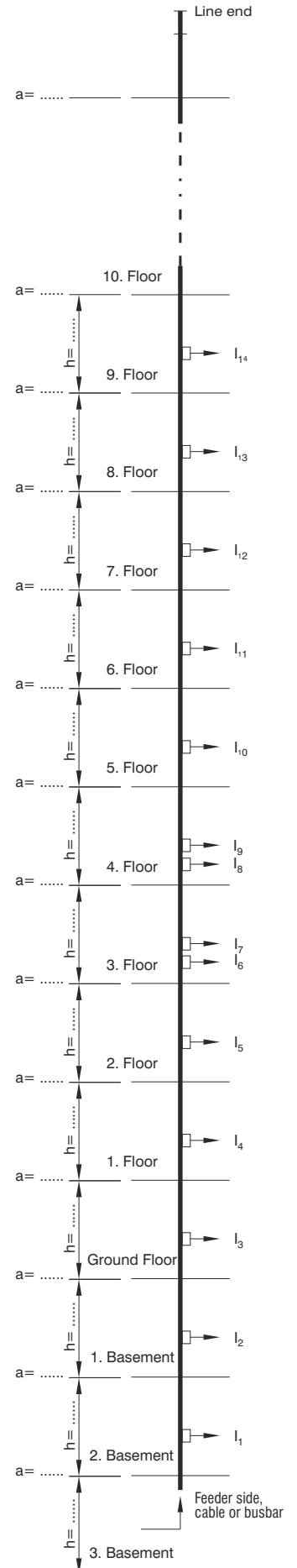
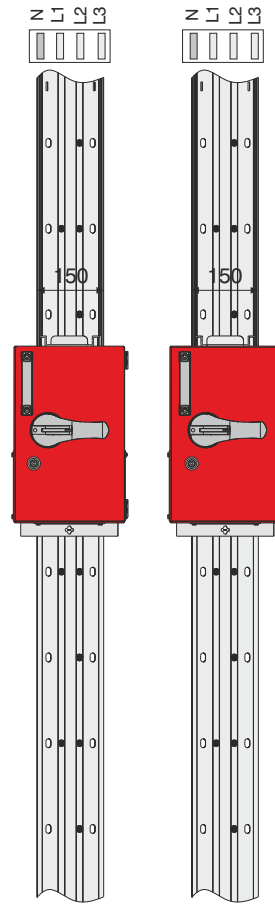
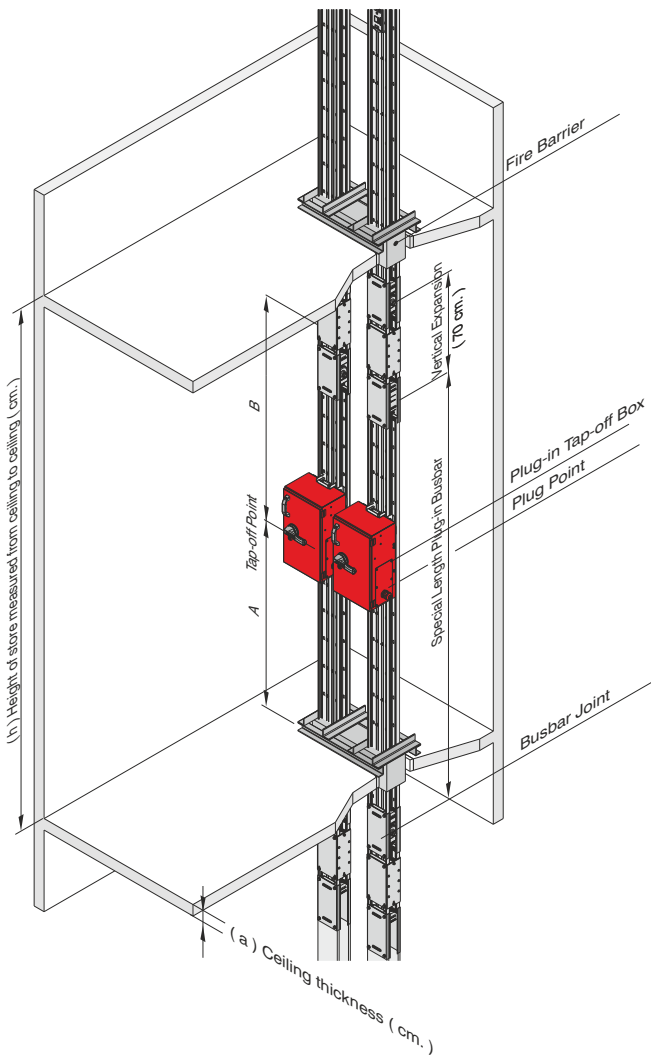

Project Design

The details below should be sent to our Project & Design department.

- Location and dimensions of the floor penetration where busbar will be installed.
- Number, height and ceiling thickness of storeys. (a=..., h=...)
- Connected load for each storey.
- Supply type of the vertical line (busbar or cable).

Please send the information to us by fax or e-mail with a sample drawing in Figure 1.

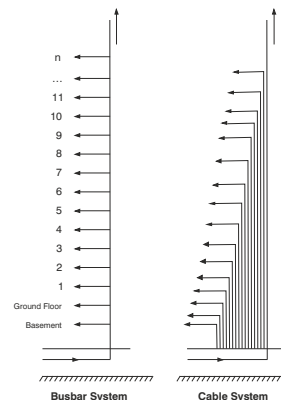

Figure 1

► Technical Characteristics
Aluminium Conductor (Al)

Standards	IEC 61439-6, TS EN 61439-6, IEC 61439-1, TS EN 61439-1															
Rated Isolation Voltage	Ui	V	1000	at Cat IV												
Max. Rated Operational Voltage	Ue	Vac	1000													
Rated Impulse Withstand Voltage	Uimp	kV	12													
Rated Frequency	f	Hz	50													
Pollution Degree	III															
Protection Degree	IP55 / IP65 / IP67															
External Mechanical Impacts (IK Code)*	Bolt-on Busbar IK09, Plug-in Busbar IK08															
Protection for Safety	Basic Protection (HD 60364-4-41, Clause A1)															

Rated Current	In	A	400	500	630	800	1000	1250	1350	1600	2000	2500	2500	3150	3200	4000	5000
---------------	----	---	-----	-----	-----	-----	------	------	------	------	------	------	------	------	------	------	------

Busbar Code			04	05	06	08	10	12	14	17	20	25	27	32	33	40	51
-------------	--	--	----	----	----	----	----	----	----	----	----	----	----	----	----	----	----

Rated Short-time Withstand Current (1s) (Three phase)	I _{cw}	kA	16	16	25	35	50	60	60	80	80	100	80	100	120	120	120
Rated Peak Withstand Current	I _{pk}	kA	32	32	52,5	73,5	105	132	132	176	176	220	176	220	264	264	264
Rated Short-time Withstand Current for Neutral Conductor (1s) (Single phase)	I _{cw}	kA	9,6	9,6	15	21	30	36	36	48	48	60	48	60	72	72	72
Rated Peak Withstand Current for Neutral Conductor	I _{pk}	kA	16,32	16,32	30	44,1	63	75,6	75,6	100,8	100,8	132	100,8	132	158,4	158,4	158,4
Rated Short-time Withstand Current for PE (Housing) Conductor (1s) (Single phase)	I _{cw}	kA	9,6	9,6	15	21	30	36	36	48	48	60	48	60	72	72	72
Rated Peak Withstand Current for PE (Housing) Conductor	I _{pk}	kA	16,32	16,32	30	44,1	63	75,6	75,6	100,8	100,8	132	100,8	132	158,4	158,4	158,4

MEAN PHASE CONDUCTOR CHARACTERISTICS AT RATED CURRENT In																	
Resistance at a conductor temperature of 20 °C	R ₂₀	mW/m	0,197	0,163	0,121	0,088	0,061	0,044	0,040	0,031	0,026	0,022	0,021	0,018	0,015	0,012	0,010
Resistance at an ambient air temperature of 35 °C	R	mW/m	0,258	0,225	0,159	0,116	0,080	0,058	0,052	0,041	0,034	0,029	0,028	0,024	0,020	0,016	0,013
Reactance (Independent from Temperature)	X	mW/m	0,035	0,033	0,027	0,021	0,015	0,013	0,013	0,010	0,008	0,007	0,007	0,005	0,005	0,004	0,003
Positive and negative sequence impedances at an ambient air temperature of 35 °C	Z	mW/m	0,260	0,227	0,162	0,118	0,082	0,060	0,053	0,042	0,035	0,030	0,029	0,024	0,020	0,017	0,014
Positive and negative sequence impedances at a conductor temperature of 20 °C	Z ₂₀	mW/m	0,200	0,167	0,124	0,091	0,063	0,046	0,042	0,033	0,027	0,023	0,022	0,018	0,016	0,013	0,010
Rated Power Loss at 35 °C		W/m	120,5	163,0	189,3	222,7	240,6	271,9	282,7	315,6	412,8	547,5	517,5	708,5	599	787,2	997,5
DC Resistance at a conductor temperature of 20 °C for Phases	R _{ortph}	mW/m	0,197	0,161	0,124	0,087	0,060	0,043	0,039	0,030	0,024	0,022	0,019	0,018	0,015	0,012	0,010
DC Resistance at a conductor temperature of 20 °C for Neutral	R _N	mW/m	0,198	0,164	0,126	0,090	0,061	0,044	0,039	0,031	0,025	0,023	0,020	0,018	0,017	0,013	0,010
DC Resistance at a conductor temperature of 20 °C for PE (Housing)	R _{PE}	mW/m	0,038	0,033	0,028	0,024	0,028	0,024	0,026	0,033	0,035	0,018	0,020	0,026	0,023	0,018	0,018

SECTIONS																	
L1,L2,L3,N		mm ²	150	180	240	330	480	660	750	960	1200	1320	1500	1680	1920	2400	3000
PE (4 ½ Conductors)		mm ²	75	90	120	165	240	330	375	480	600	660	750	840	960	1200	1500
PE (5 Conductors)		mm ²	150	180	240	330	480	660	750	960	1200	1320	1500	1680	1920	2400	3000
Aluminium Housing Section (Aluminium)		mm ²	1449	1509	1686	1788	1894	2050	2128	2314	2518	3912	2764	4224	4411	4848	5275
Conductor Dimensions		mmxmm	6x25	6x30	6x40	6x55	6x80	6x110	6x125	6x160	6x200	2(6x110)	6x250	2(6x140)	2(6x160)	2(6x200)	2(6x250)
Busbar Weight (4 Conductors)		kg/m	7,0	7,4	7,9	9,2	11,3	13,9	15,2	18,3	21,7	27,3	28,5	32,5	35,9	42,9	70,0
Busbar Weight (5 Conductors)		kg/m	7,4	7,9	8,6	10,2	12,8	15,9	17,5	21,1	25,3	31,2	34,2	37,5	41,6	50	81,6

MEAN FAULT-LOOP CHARACTERISTICS

Zero-sequence Impedance																	
Zero-sequence impedance at a conductor temperature of 20 °C	Z _{(0)b20phN}	mW/m	0,873	0,748	0,572	0,419	0,291	0,214	0,194	0,153	0,130	0,108	0,103	0,086	0,074	0,060	0,048
Zero-sequence impedance at a conductor temperature of 20 °C (Housing)	Z _{(0)b20phPE}	mW/m	0,430	0,398	0,326	0,268	0,245	0,208	0,199	0,161	0,158	0,101	0,131	0,092	0,101	0,084	0,078
Zero-sequence impedance at an ambient temperature of 35 °C	Z _{(0)bphN}	mW/m	1,129	1,011	0,742	0,540	0,371	0,274	0,245	0,195	0,167	0,140	0,135	0,113	0,094	0,078	0,064
Zero-sequence impedance at an ambient temperature of 35 °C (Housing)	Z _{(0)bphPE}	mW/m	0,528	0,507	0,406	0,331	0,303	0,260	0,245	0,199	0,199	0,126	0,168	0,119	0,127	0,108	0,102

Resistances and Reactances																	
Resistance at a conductor temperature of 20 °C	R _{b20phph}	mW/m	0,399	0,337	0,249	0,184	0,125	0,092	0,083	0,065	0,054	0,046	0,042	0,036	0,031	0,025	0,020
Resistance at a conductor temperature of 20 °C	R _{b20phN}	mW/m	0,408	0,347	0,255	0,192	0,131	0,096	0,087	0,069	0,057	0,049	0,044	0,038	0,033	0,027	0,021
Resistance at a conductor temperature of 20 °C (Housing)	R _{b20phPE}	mW/m	0,252	0,223	0,175	0,137	0,112	0,093	0,086	0,068	0,065	0,053	0,050	0,039	0,049	0,035	0,031
Resistance at an ambient air temperature of 35 °C	R _{bphph}	mW/m	0,523	0,464	0,328	0,241	0,164	0,120	0,107	0,086	0,072	0,059	0,057	0,049	0,040	0,033	0,027
Resistance at an ambient air temperature of 35 °C	R _{bphN}	mW/m	0,534	0,477	0,336	0,252	0,171	0,126	0,113	0,090	0,076	0,062	0,060	0,052	0,043	0,035	0,029
Resistance at an ambient air temperature of 35 °C (Housing)	R _{bphPE}	mW/m	0,330	0,307	0,231	0,180	0,146	0,122	0,112	0,089	0,086	0,067	0,068	0,052	0,064	0,046	0,042
Reactance (Independent from temperature)	X _{bphph}	mW/m	0,073	0,065	0,043	0,042	0,032	0,024	0,023	0,018	0,017	0,012	0,013	0,010	0,009	0,008	0,005
Reactance (Independent from temperature)	X _{bphN}	mW/m	0,102	0,092	0,075	0,058	0,045	0,034	0,032	0,026	0,023	0,018	0,020	0,014	0,013	0,012	0,009
Reactance (Independent from temperature)	X _{bphPE}	mW/m	0,102	0,093	0,069	0,061	0,050	0,041	0,039	0,032	0,030	0,024	0,023	0,017	0,019	0,015	0,014

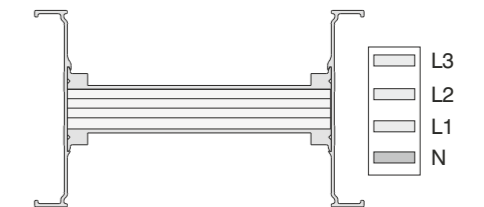
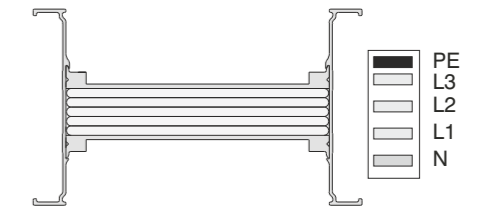

Voltage Drop Calculation
Generally Voltage drop of a busbar system can be calculated with the following formula.

$$DU = \sqrt{3} \cdot L \cdot I \cdot (R \cdot \cos\phi + X \cdot \sin\phi) \cdot 10^{-3} \text{ [V]}$$

- DU = Voltage Drop (V)
- L = Line Length (m)
- I = Line Current or Load (A)
- R = Resistance (mW/m)
- X = Reactance (mW/m)

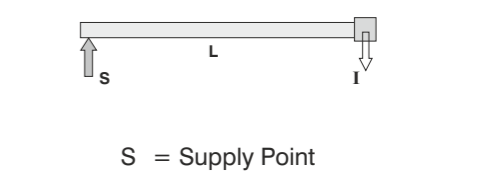

- All phase conductor characteristics had been determined according to Annex BB of IEC / EN 61439-6.
- Fault-loop zero-sequences impedances had been determined according to Annex CC of IEC / EN 61439-6.
- Fault-loop resistances and impedances had been determined according to Annex DD of IEC / EN 61439-6.
- * IK10 corresponds to impact energy of 20J according to IEC 62262.

►► Technical Characteristics
Copper Conductor (Cu)

Standards	IEC 61439-6, TS EN 61439-6, IEC 61439-1, TS EN 61439-1																
Rated Isolation Voltage	Ui	V	1000	at Cat IV													
Max. Rated Operational Voltage	Ue	Vac	1000														
Rated Impulse Withstand Voltage	Uimp	kV	12														
Rated Frequency	f	Hz	50														
Pollution Degree	III																
Protection Degree	IP55 / IP65 / IP67																
External Mechanical Impacts (IK Code)*	Bolt-on Busbar IK09, Plug-in Busbar IK08																
Protection for Safety	Basic Protection (HD 60364-4-41, Clause A1)																

Rated Current	In	A	550	650	800	1000	1250	1350	1600	2000	2500	2000	2500	3300	3600	4000	5000	6300
----------------------	-----------	----------	------------	------------	------------	-------------	-------------	-------------	-------------	-------------	-------------	-------------	-------------	-------------	-------------	-------------	-------------	-------------

Busbar Code			05	06	08	10	12	14	17	23	25	22	27	32	36	40	50	63
--------------------	--	--	-----------	-----------	-----------	-----------	-----------	-----------	-----------	-----------	-----------	-----------	-----------	-----------	-----------	-----------	-----------	-----------

Rated Short-time Withstand Current (1s) (Three phase)	I _{cw}	kA	24	24	40	50	60	60	80	80	100	80	100	120	120	120	120	120
Rated Peak Withstand Current	I _{pk}	kA	50,4	50,4	84	105	132	132	176	176	220	176	220	264	264	264	264	264
Rated Short-time Withstand Current for Neutral Conductor (1s) (Single phase)	I _{cw}	kA	14,4	14,4	24	30	36	36	48	48	60	48	60	72	72	72	72	72
Rated Peak Withstand Current for Neutral Conductor	I _{pk}	kA	28,8	28,8	50,4	63	75,6	75,6	100,8	100,8	132	100,8	132	158,4	158,4	158,4	158,4	158,4
Rated Short-time Withstand Current for PE (Housing) Conductor (1s) (Single phase)	I _{cw}	kA	14,4	14,4	24	30	36	36	48	48	60	48	60	72	72	72	72	72
Rated Peak Withstand Current for PE (Housing) Conductor	I _{pk}	kA	28,8	28,8	50,4	63	75,6	75,6	100,8	100,8	132	100,8	132	158,4	158,4	158,4	158,4	158,4

MEAN PHASE CONDUCTOR CHARACTERISTICS AT RATED CURRENT In																		
Resistance at a conductor temperature of 20 °C	R ₂₀	mW/m	0,123	0,100	0,074	0,055	0,044	0,038	0,032	0,024	0,016	0,028	0,021	0,014	0,012	0,011	0,008	0,005
Resistance at an ambient air temperature of 35 °C	R	mW/m	0,162	0,137	0,097	0,071	0,057	0,050	0,044	0,033	0,021	0,036	0,028	0,019	0,016	0,015	0,010	0,006
Reactance (Independent from Temperature)	X	mW/m	0,044	0,034	0,028	0,023	0,019	0,016	0,015	0,010	0,008	0,012	0,009	0,007	0,006	0,005	0,004	0,003
Positive and negative sequence impedances at an ambient air temperature of 35 °C	Z	mW/m	0,168	0,141	0,101	0,075	0,060	0,053	0,047	0,034	0,022	0,038	0,030	0,020	0,017	0,016	0,011	0,007
Positive and negative sequence impedances at a conductor temperature of 20 °C	Z ₂₀	mW/m	0,130	0,106	0,079	0,060	0,047	0,041	0,035	0,026	0,018	0,030	0,023	0,016	0,014	0,012	0,009	0,006
Rated Power Loss at 35 °C		W/m	143,5	166,8	185,5	213,6	264,8	274,5	325,1	383,3	384,4	436,8	528,8	604,4	633,7	705,6	772,5	750,1
DC Resistance at a conductor temperature of 20 °C for Phases	R _{ortph}	mW/m	0,118	0,097	0,072	0,053	0,041	0,036	0,031	0,022	0,014	0,025	0,021	0,013	0,012	0,010	0,007	0,005
DC Resistance at a conductor temperature of 20 °C for Neutral	R _N	mW/m	0,120	0,099	0,074	0,054	0,042	0,036	0,031	0,023	0,014	0,026	0,021	0,015	0,012	0,009	0,008	0,005
DC Resistance at a conductor temperature of 20 °C for PE (Housing)	R _{PE}	mW/m	0,036	0,034	0,027	0,029	0,024	0,028	0,028	0,039	0,031	0,019	0,022	0,018	0,023	0,021	0,021	0,011

SECTIONS																		
L1,L2,L3,N		mm ²	150	180	240	330	420	480	570	750	1200	660	840	1320	1500	1680	2400	3600
PE (4 ½ Conductors)		mm ²	75	90	120	165	210	240	285	375	600	330	420	660	750	840	1200	1800
PE (5 Conductors)		mm ²	150	180	240	330	420	480	570	750	1200	660	840	1320	1500	1680	2400	3600
Aluminium Housing Section (Aluminium)		mm ²	1449	1509	1686	1788	1842	1894	1996	2128	2518	3340	3580	3912	4068	4224	4848	7128
Conductor Dimensions		mmxmm	6x25	6x30	6x40	6x55	6x70	6x80	6x95	6x125	6x200	2(6x55)	2(6x70)	2(6x110)	2(6x125)	2(6x140)	2(6x200)	3(6x200)
Busbar Weight (4 Conductors)		kg/m	10,7	11,9	14,4	18,3	22	24,5	27,7	36,2	54,7	35,9	44	63,5	71,1	78,6	108,8	162,8
Busbar Weight (5 Conductors)		kg/m	12,2	13,52	16,8	21,5	26,1	29,2	33,7	43,8	66,5	42,4	52	76,5	85,8	95,2	132,4	198,2

MEAN FAULT-LOOP CHARACTERISTICS																		
Zero-sequence Impedance																		
Zero-sequence impedance at a conductor temperature of 20 °C	Z _{(0)b20phN}	mW/m	0,585	0,489	0,393	0,295	0,250	0,198	0,168	0,130	0,086	0,148	0,107	0,073	0,067	0,060	0,038	0,029
Zero-sequence impedance at a conductor temperature of 20 °C (Housing)	Z _{(0)b20phPE}	mW/m	0,365	0,338	0,268	0,281	0,229	0,209	0,154	0,153	0,146	0,144	0,090	0,091	0,090	0,100	0,086	0,061
Zero-sequence impedance at an ambient temperature of 35 °C	Z _{(0)bphN}	mW/m	0,750	0,646	0,499	0,371	0,309	0,251	0,221	0,167	0,107	0,189	0,136	0,092	0,084	0,077	0,046	0,034
Zero-sequence impedance at an ambient temperature of 35 °C (Housing)	Z _{(0)bphPE}	mW/m	0,442	0,419	0,324	0,345	0,286	0,259	0,197	0,193	0,181	0,176	0,111	0,113	0,112	0,128	0,106	0,075
Resistances and Reactances																		
Resistance at a conductor temperature of 20 °C	R _{b20phph}	mW/m	0,248	0,206	0,159	0,119	0,091	0,077	0,066	0,050	0,033	0,059	0,044	0,029	0,025	0,023	0,016	0,011
Resistance at a conductor temperature of 20 °C	R _{b20phN}	mW/m	0,256	0,214	0,167	0,126	0,097	0,083	0,071	0,054	0,035	0,063	0,047	0,031	0,027	0,025	0,017	0,012
Resistance at a conductor temperature of 20 °C (Housing)	R _{b20phPE}	mW/m	0,176	0,155	0,123	0,112	0,137	0,083	0,065	0,059	0,053	0,061	0,040	0,035	0,034	0,044	0,032	0,023
Resistance at an ambient air temperature of 35 °C	R _{bphph}	mW/m	0,328	0,283	0,209	0,154	0,118	0,103	0,091	0,067	0,043	0,077	0,058	0,038	0,033	0,030	0,020	0,013
Resistance at an ambient air temperature of 35 °C	R _{bphN}	mW/m	0,339	0,294	0,219	0,163	0,126	0,110	0,098	0,073	0,046	0,083	0,062	0,041	0,036	0,033	0,022	0,015
Resistance at an ambient air temperature of 35 °C (Housing)	R _{bphPE}	mW/m	0,233	0,213	0,161	0,145	0,178	0,111	0,089	0,080	0,070	0,080	0,052	0,047	0,044	0,059	0,041	0,028
Reactance (Independent from temperature)	X _{bphph}	mW/m	0,079	0,069	0,052	0,043	0,036	0,032	0,026	0,022	0,014	0,022	0,016	0,012	0,011	0,010	0,008	0,005
Reactance (Independent from temperature)	X _{bphN}	mW/m	0,105	0,094	0,071	0,059	0,050	0,045	0,037	0,032	0,022	0,029	0,023	0,018	0,015	0,014	0,011	0,008
Reactance (Independent from temperature)	X _{bphPE}	mW/m	0,101	0,093	0,070	0,061	0,054	0,050	0,036	0,035	0,028	0,033	0,022	0,020	0,018	0,018	0,014	0,010

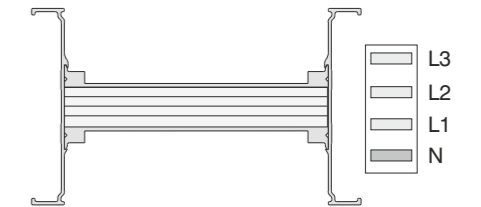
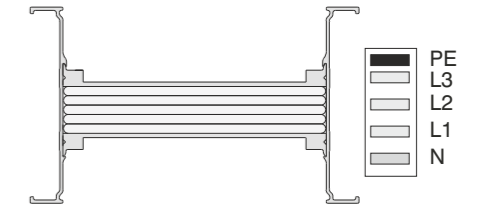

Voltage Drop Calculation
Generally Voltage drop of a busbar system can be calculated with the following formula.

$$DU = \sqrt{3} \cdot L \cdot I \cdot (R \cdot \cos\phi + X \cdot \sin\phi) \cdot 10^{-3} \text{ [V]}$$

- DU = Voltage Drop (V)
- L = Line Length (m)
- I = Line Current or Load (A)
- R = Resistance (mW/m)
- X = Reactance (mW/m)

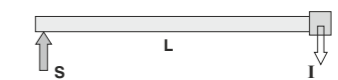

S = Supply Point

- All phase conductor characteristics had been determined according to Annex BB of IEC / EN 61439-6.
 - Fault-loop zero-sequences impedances had been determined according to Annex CC of IEC / EN 61439-6.
 - Fault-loop resistances and impedances had been determined according to Annex DD of IEC / EN 61439-6.
- * IK10 corresponds to impact energy of 20J according to IEC 62262.

BUSBAR TYPE
 CONDUCTOR MATERIAL
 BUSBAR CODE
 PROTECTION DEGREE
 CONDUCTOR CONFIGURATION
 UTILIZATION TYPE P - Plug-in / B - Bolt-on
 COMPONENT

KX A 17 5 04 - B - TR 4 1

Busbar Type

Aluminium (Al) **A**
 Copper (Cu) **C**

CONDUCTOR MATERIAL

KXA - Al Conductor		KXC - Cu Conductor		Conductor Size
Rated Current	Busbar Code	Rated Current	Busbar Code	
*400	04	*550	05	6x25
*500	05	*650	06	6x30
*630	06	*800	08	6x40
800	08	1000	10	6x55
-	-	1250	12	6x70
1000	10	1350	14	6x80
-	-	1600	17	6x95
1250	12	-	-	6x110
1350	14	2000	23	6x125
1600	17	-	-	6x160
2000	20	2500	25	6x200
2500	27	-	-	6x250
-	-	2000	22	2(6x55)
-	-	2500	27	2(6x70)
2500	25	3300	32	2(6x110)
-	-	3600	36	2(6x125)
3150	32	4000	40	2(6x140)
3200	33	-	-	2(6x160)
4000	40	5000	50	2(6x200)
5000	51	-	-	2(6x250)
-	-	6300	63	3(6x200)

(*) Bolt-on tap-off box can not be used on the joints of mentioned ratings of busbars. Plug-in points can be **at one side only**.

BUSBAR CODE

IP55/IP65* **5**
 IP67 **6**

PROTECTION DEGREE

*Please call us for IP65 orders.

Number of Conductors	Code	Conductor Configuration								
		L1	L2	L3	N	1/2 PE	CPE	1/2 CPE	PE (Housing)	
3 Conductors	03	✓	✓	✓					✓	
4 Conductors	04	✓	✓	✓	✓				✓	
4 1/2 Conductors	07	✓	✓	✓	✓		✓		✓	
4 1/2 Conductors	08	✓	✓	✓	✓			✓	✓	
5 Conductors	05	✓	✓	✓	✓	✓			✓	
5 Conductors	09	✓	✓	✓	✓		✓		✓	

***TYPE** Utilization Type

(B) Bolt-on Energy is supplied from the joints.

(P) Plug-in Energy is supplied from the joints and the plug-in points.

COMPONENTS

Standard Length	STD
Special Length	X
Upwards Elbow	U
Downwards Elbow	D
Right Elbow	R
Left Elbow	L
Left Horizontal Offset	LH
Right Horizontal Offset	RH
Upwards Vertical Offset	UV
Downwards Vertical Offset	DV
Upwards Left Combined Offset	KUL
Upwards Right Combined Offset	KUR
Downwards Left Combined Offset	KDL
Downwards Right Combined Offset	KDR
Left Upwards Combined Offset	KLU
Right Upwards Combined Offset	KRU
Left Downwards Combined Offset	KLD
Right Downwards Combined Offset	KRD
End Closer	S
Reduction	RD
Left Side Feeder "T"	TYL
Right Side Feeder "T"	TYR
Central Feeder "T"	TO
Horizontal Expansion	YDT
Vertical Expansion	DDT
Phase Transposition Module	FDM
Panel Connection	P10
Panel Connection	P11
Upwards Panel Connection	PU20
Upwards Panel Connection	PU21
Downwards Panel Connection	PD20
Downwards Panel Connection	PD21
Right Panel Connection	PR30
Right Panel Connection	PR31
Left Panel Connection	PL30
Left Panel Connection	PL31
Panel Connection	P40
Panel Connection	P41
Transformer Connection	TR11
Upwards Transformer Connection	TU21
Downwards Transformer Connection	TD21
Transformer Connection	TR31
Transformer Connection	TR41
Right Transformer Connection	TR51
Left Transformer Connection	TL51
Transformer Connection	TR61
Transformer Connection	TR71
Feeder Box	B10
Feeder Box	B11
Central Feeder Box	BO
Flexible	F

►► Standard Straight Length

- BUSBAR TYPE
- CONDUCTOR MATERIAL
- BUSBAR CODE
- PROTECTION DEGREE
- CONDUCTOR CONFIGURATION
- UTILIZATION TYPE P - Plug-in / B - Bolt-on
- COMPONENT



Bolt-on

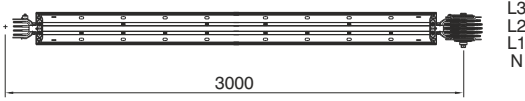

Electrical energy up to 1000 A can be supplied from the joints of bolt-on type by bolt-on tap-off boxes.

Note:

Busbar energy should be turned off, before installing bolt-on type tap-off boxes.

Plug-in

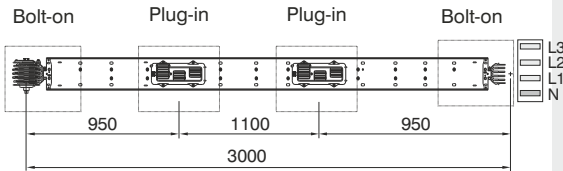

Electrical energy up to 1000 A can be supplied from the joints and up to 630 A can be supplied from the plus.

Note:

Please, determine number and side of plug-in points (single or double side).

Table For Outer Dimension of Busbars

KXA - Al Conductor		KXC - Cu Conductor		A (mm)
Rated Current	Busbar Code	Rated Current	Busbar Code	
* 400	04	* 550	05	77,5
* 500	05	* 650	06	82,5
* 630	06	* 800	08	91
800	08	1000	10	106
-	-	1250	12	121
1000	10	1350	14	131
-	-	1600	17	146
1250	12	-	-	161
1350	14	2000	23	176
1600	17	-	-	211
2000	20	2500	25	251
2500	27	-	-	301

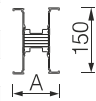

-	-	2000	22	202
-	-	2500	27	232
2500	25	3300	32	312
-	-	3600	36	342
3150	32	4000	40	372
3200	33	-	-	412
4000	40	5000	50	492
5000	51	-	-	592

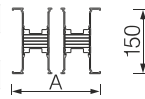

-	-	6300	63	732
---	---	------	----	-----

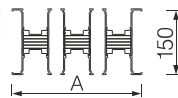

Important Notice for the Tap-off box use;

*It is not possible to install tap-off box at joint side for KXA 400A,500A,KXA 630A, KXC 550A,KXC 650A and KXC 800A. KXA 400A,500A,KXA 630A,KXC 550A,KXC 650A and KXC 800A busbar range may have plug-in windows at one side only. It is highly recommended to consider these points in your project designs.

Bolt-on Standard - STD Straight Length Busbar

Sample Order:

2500 A, Aluminium, Bolt-on, IP 55, 4 conductors

KXA 25504 - B - STD

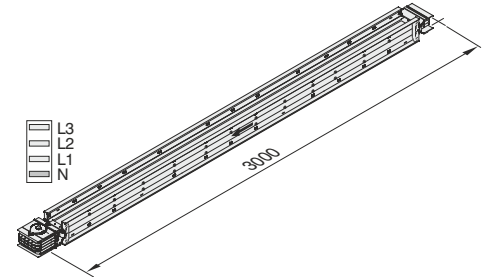

Applications:

- As feeder or sub-feeder line,
- Where a load has to be supplied from the busbar.

Plug-in Standard - STD Straight Length Busbar

Sample Order:

1250 A, Copper, Plug-in, IP 55, 4 conductors

KXC 12504 - P - STD

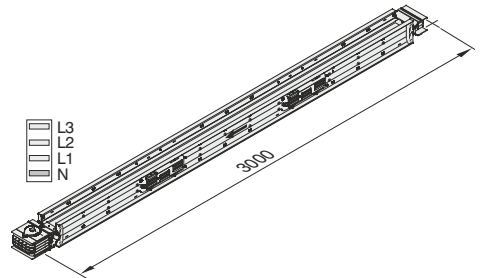

Applications:

- In application of bolt-on
- As vertical feeder line high rise buildings
- For frequent energy supply
- If continuous energy needed, while tap-offs installed.

Special Straight Length



Special Straight Length in (cm)

Sample Order:

2500 A, Copper, Bolt-on, IP 55, 4 conductors, 147cm

KXC 25504 - B - X - 147

Note:

Bolt-on Minimum Length = 35cm
Plug-in Minimum Length = 100cm

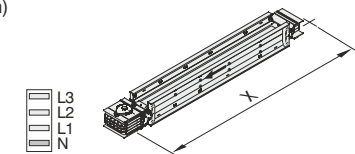

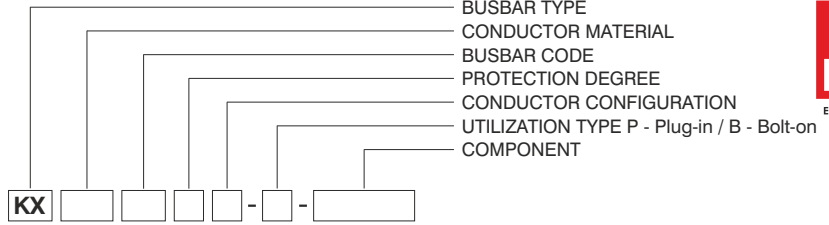

Upwards Elbow - U

Sample Order:

3300 A, Copper, Bolt-on, IP 55,
4 conductors

KXC 32504 - B - U

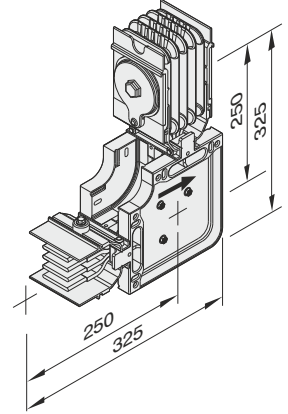

Downwards Elbow - D

Sample Order:

3300 A, Copper, Bolt-on, IP 55,
4 conductors

KXC 32504 - B - D

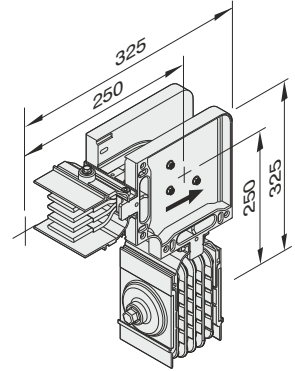

Left Elbow - L

Sample Order:

2000 A, Copper, Bolt-on, IP 55,
4 conductors

KXC 20504 - B - L

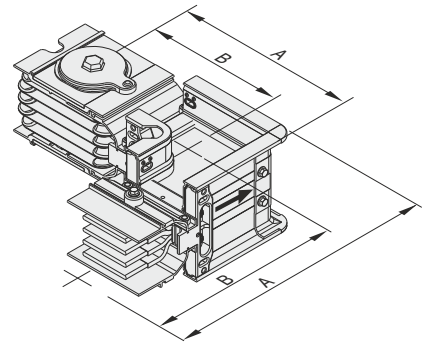

Right Elbow - R

Sample Order:

2000 A, Aluminium, Bolt-on, IP 55,
4 conductors

KXA 20504 - B - R

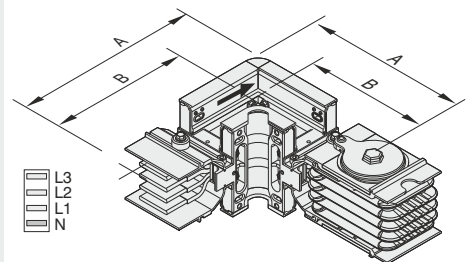

KXA - Al Conductor		KXC - Cu Conductor		A	B
Rated Current	Busbar Code	Rated Current	Busbar Code	(mm)	(mm)
400	04	550	05	252	214
500	05	650	06	257	217
630	06	800	08	267	222
800	08	1000	10	282	229
-	-	1250	12	297	236
1000	10	1350	14	307	241
-	-	1600	17	322	249
1250	12	-	-	337	256
1350	14	2000	23	352	264
1600	17	-	-	387	281
2000	20	2500	25	427	301
2500	27	-	-	477	326
-	-	2000	22	377	276
-	-	2500	27	407	291
2500	25	3300	32	487	331
-	-	3600	36	517	346
3150	32	4000	40	547	361
3200	33	-	-	587	381
4000	40	5000	50	667	421
5000	51	-	-	767	471
-	-	6300	63	907	541

■ Special left or right elbows between 90° and 180° can be manufactured upon request.

■ The dimensions given above are minimum values. ■ Please call us for non-standard components.

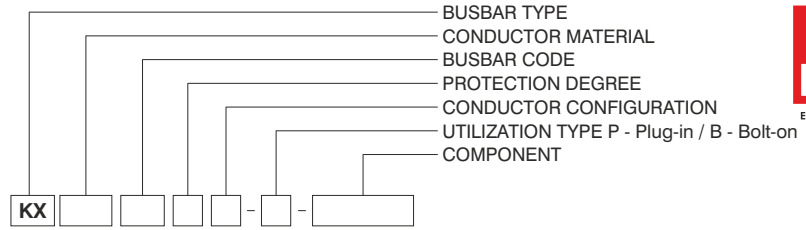

Left Horizontal Offset - LH

Sample Order:

X=60 cm, 3300 A, Copper Bolton, IP 55, 4 conductors

KXC 32504-B-LH60 - LH

Note:
X=min:28 cm,
max: *Please see table.
Used, if two horizontal elbows can not fit.

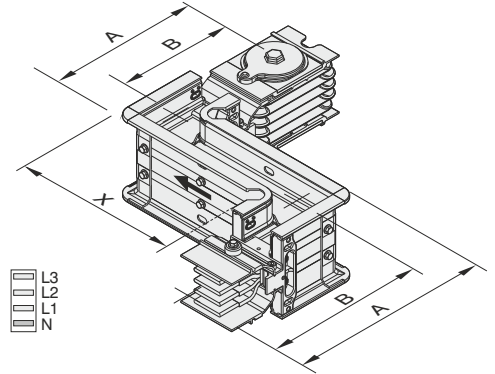

Right Horizontal Offset - RH

Sample Order:

X=60 cm, 3300 A, Copper Bolton, IP 55, 4 conductors

KXC 32504-B-RH60 - RH

Note:
X=min:28 cm,
max: *Please see table.
Used, if two horizontal elbows can not fit.

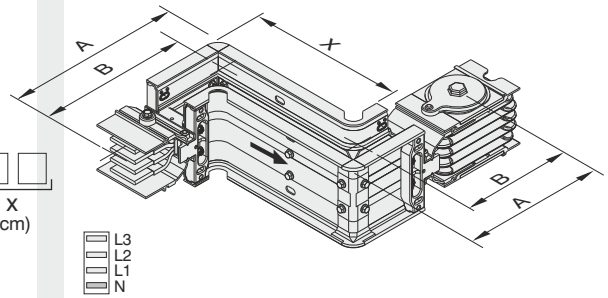

Upwards Vertical Offset - UV

Sample Order:

Y=25 cm, 2000 A, Aluminium Bolt-on, IP 55, 5 conductors

KXA 20505-B-UV25 - UV

Note:
Y=min:25 cm max:49 cm

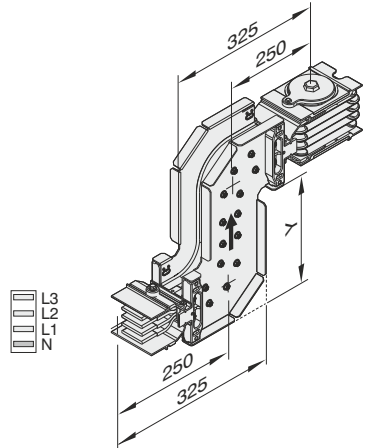

Downwards Vertical Offset - DV

Sample Order:

Y=25 cm, 2000 A, Aluminium Bolt-on, IP 55, 5 conductors

KXA 20505-B-DV25 - DV

Note:
Y=min:25 cm max:49 cm

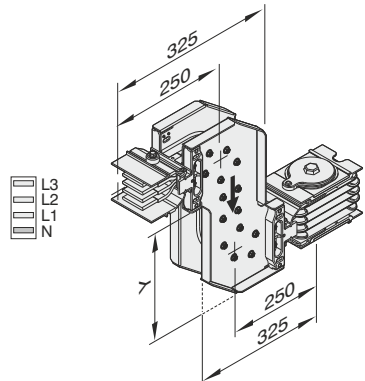

KXA - Al Conductor		KXC - Cu Conductor		A	B	X _{max}
Rated Current	Busbar Code	Rated Current	Busbar Code	(mm)	(mm)	(mm)
400	04	550	05	252	214	427
500	05	650	06	257	217	432
630	06	800	08	267	222	442
800	08	1000	10	282	229	457
-	-	1250	12	297	236	472
1000	10	1350	14	307	241	482
-	-	1600	17	322	249	497
1250	12	-	-	337	256	512
1350	14	2000	23	352	264	527
1600	17	-	-	387	281	562
2000	20	2500	25	427	301	602
2500	27	-	-	477	326	652
-	-	2000	22	377	276	552
-	-	2500	27	407	291	582
2500	25	3300	32	487	331	662
-	-	3600	36	517	346	692
3150	32	4000	40	547	361	722
3200	33	-	-	587	381	762
4000	40	5000	50	667	421	842
5000	51	-	-	767	471	942
-	-	6300	63	907	541	1082

- Special left or right offsets between 90° and 180° can be manufactured upon request.
- The dimensions given above are minimum values. ■ Please call us for non-standard components.

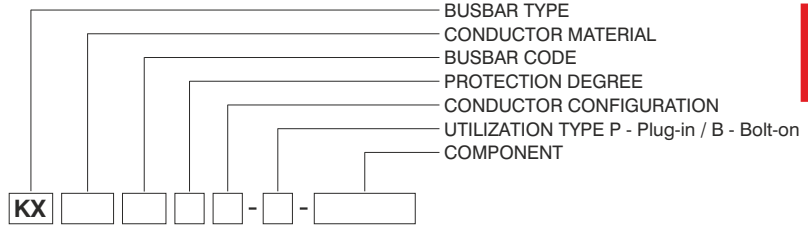

Upwards Left Combined Offset - K U L

Sample Order:
3300 A, Copper
Bolt-on, IP 55, 4 conductors

KXC 32504 - B - KUL

Note:
Y= min. 30 cm

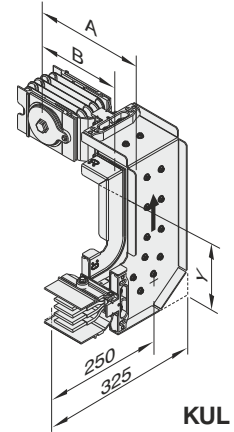

KUL

Upwards Right Combined Offset - K U R

Sample Order:
3200 A, Aluminium
Bolt-on, IP 55, 4 conductors

KXA 33504 - B - KUR

Note:
Y= min. 30 cm

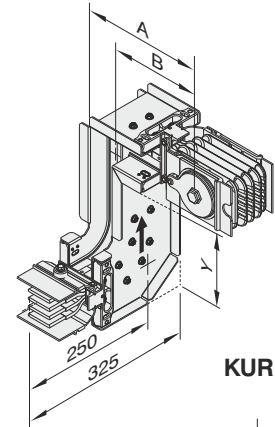

KUR

Downwards Left Combined Offset - K D L

Sample Order:
3300 A, Copper
Bolt-on, IP 55, 4 conductors

KXC 32504 - B - KDL

Note:
Y= min. 30 cm

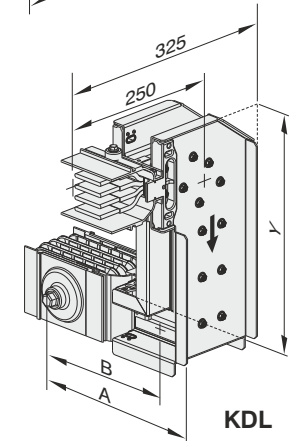

KDL

Downwards Right Combined Offset - K D R

Sample Order:
3200 A, Aluminium
Bolt-on, IP 55, 4 conductors

KXA 33504 - B - KDR

Note:
Y= min. 30 cm

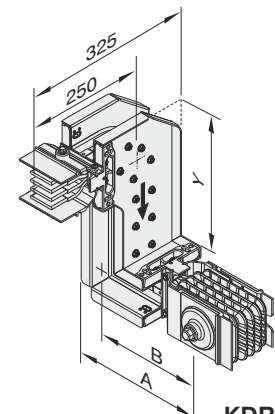

KDR

KXA - Al Conductor		KXC - Cu Conductor		A	B
Rated Current	Busbar Code	Rated Current	Busbar Code	(mm)	(mm)
400	04	550	05	252	214
500	05	650	06	257	217
630	06	800	08	267	222
800	08	1000	10	282	229
-	-	1250	12	297	236
1000	10	1350	14	307	241
-	-	1600	17	322	249
1250	12	-	-	337	256
1350	14	2000	23	352	264
1600	17	-	-	387	281
2000	20	2500	25	427	301
2500	27	-	-	477	326
-	-	2000	22	377	276
-	-	2500	27	407	291
2500	25	3300	32	487	331
-	-	3600	36	517	346
3150	32	4000	40	547	361
3200	33	-	-	587	381
4000	40	5000	50	667	421
5000	51	-	-	767	471
-	-	6300	63	907	541

- Please call us for non-standard components.
- The dimensions given above are minimum values.

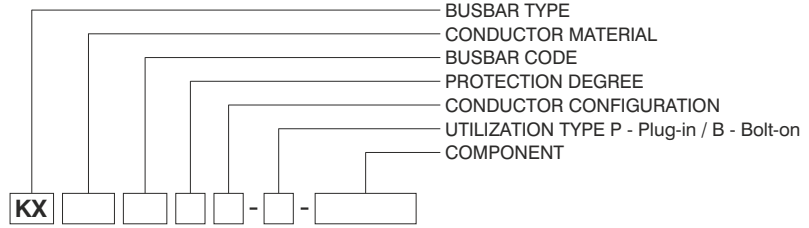

Left Upwards Combined Offset - K L U

Sample Order:
3200 A, Aluminium
Bolt-on, IP 55, 4 conductors

KXA 33504 - B - KLU

Note:
Y = min. 30 cm

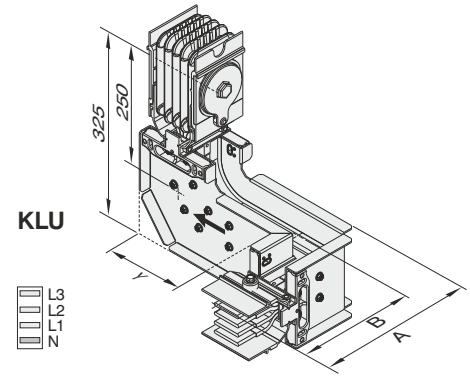

Right Upwards Combined Offset - K R U

Sample Order:
3300 A, Copper
Bolt-on, IP 55, 4 conductors

KXC 32504 - B - KRU

Note:
Y = min. 30 cm

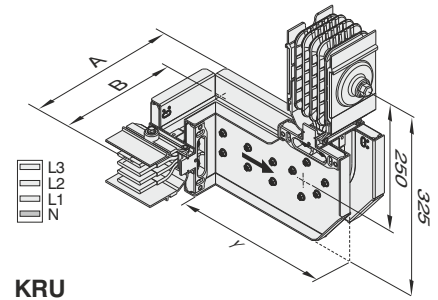

Left Downwards Combined Offset - K L D

Sample Order:
3200 A, Aluminium
Bolt-on, IP 55, 4 conductors

KXA 33504 - B - KLD

Note:
Y = min. 30 cm

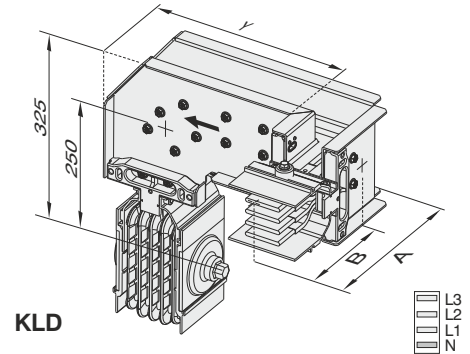

Right Downwards Combined Offset - K R D

Sample Order:
3300 A, Copper
Bolt-on, IP 55, 4 conductors

KXC 32504 - B - KR D

Note:
Y = min. 30 cm

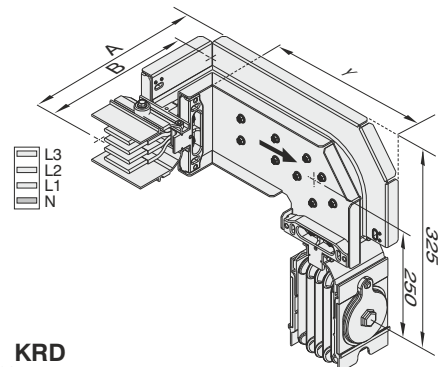

KXA - Al Conductor		KXC - Cu Conductor		A	B
Rated Current	Busbar Code	Rated Current	Busbar Code	(mm)	(mm)
400	04	550	05	252	214
500	05	650	06	257	217
630	06	800	08	267	222
800	08	1000	10	282	229
-	-	1250	12	297	236
1000	10	1350	14	307	241
-	-	1600	17	322	249
1250	12	-	-	337	256
1350	14	2000	23	352	264
1600	17	-	-	387	281
2000	20	2500	25	427	301
2500	27	-	-	477	326
-	-	2000	22	377	276
-	-	2500	27	407	291
2500	25	3300	32	487	331
-	-	3600	36	517	346
3150	32	4000	40	547	361
3200	33	-	-	587	381
4000	40	5000	50	667	421
5000	51	-	-	767	471
-	-	6300	63	907	541

■ Please call us for non-standard components.
■ The dimensions given above are minimum values.

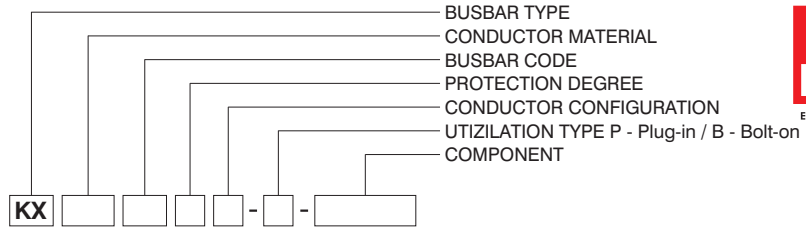

Reduction

Is used to change the busbar cross section.

NOTE:

Decisions and selection of reduction module and protection on lower side is under the customer's responsibility.

Reduction

Sample Order:

2000A / 1600A, Aluminium, Bolt-on, IP 55, 4 conductors

KXA 20504 - B - RD17

- RD

Reduced Busbar Current

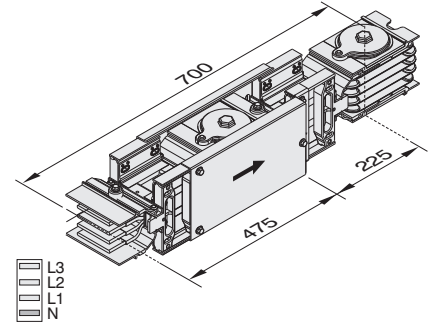

Reducers Table

KXA - Al Conductor

Rated Current	Reduced Busbar Current													
	04	05	06	08	10	12	14	17	20	25	27	32	33	40
500	✓	-	-	-	-	-	-	-	-	-	-	-	-	-
630	✓	✓	-	-	-	-	-	-	-	-	-	-	-	-
800	-	✓	✓	-	-	-	-	-	-	-	-	-	-	-
1000	-	-	✓	✓	-	-	-	-	-	-	-	-	-	-
1250	-	-	-	✓	✓	-	-	-	-	-	-	-	-	-
1350	-	-	-	-	✓	✓	-	-	-	-	-	-	-	-
1600	-	-	-	-	-	✓	✓	-	-	-	-	-	-	-
2000	-	-	-	-	-	-	✓	✓	-	-	-	-	-	-
2500	-	-	-	-	-	-	-	✓	✓	-	-	-	-	-
2500	-	-	-	-	-	-	-	-	✓	✓	-	-	-	-
3150	-	-	-	-	-	-	-	-	✓	✓	✓	-	-	-
3200	-	-	-	-	-	-	-	-	-	✓	✓	✓	-	-
4000	-	-	-	-	-	-	-	-	-	-	✓	✓	✓	✓
5000	-	-	-	-	-	-	-	-	-	-	-	-	✓	✓

KXC - Cu Conductor

Rated Current	Reduced Busbar Current														
	05	06	08	10	12	14	17	22	23	25	27	32	36	40	50
650	✓	-	-	-	-	-	-	-	-	-	-	-	-	-	-
800	✓	✓	-	-	-	-	-	-	-	-	-	-	-	-	-
1000	-	✓	✓	-	-	-	-	-	-	-	-	-	-	-	-
1250	-	-	✓	✓	-	-	-	-	-	-	-	-	-	-	-
1350	-	-	-	✓	✓	-	-	-	-	-	-	-	-	-	-
1600	-	-	-	-	✓	✓	-	-	-	-	-	-	-	-	-
2000	-	-	-	-	-	✓	✓	-	-	-	-	-	-	-	-
2000	-	-	-	-	-	-	✓	✓	-	-	-	-	-	-	-
2500	-	-	-	-	-	-	-	✓	✓	-	-	-	-	-	-
2500	-	-	-	-	-	-	-	-	✓	✓	-	-	-	-	-
3300	-	-	-	-	-	-	-	-	-	✓	✓	-	-	-	-
3600	-	-	-	-	-	-	-	-	-	-	✓	✓	✓	-	-
4000	-	-	-	-	-	-	-	-	-	-	-	✓	✓	✓	-
5000	-	-	-	-	-	-	-	-	-	-	-	-	-	✓	✓
6300	-	-	-	-	-	-	-	-	-	-	-	-	-	-	✓

See table below for ratings and busbar codes.

KXA - Al Conductor		KXC - Cu Conductor		A	B	C
Rated Current	Busbar Code	Rated Current	Busbar Code	(mm)	(mm)	(mm)
400	04	550	05	214	214	214
500	05	650	06	216	216	216
630	06	800	08	221	221	221
800	08	1000	10	229	229	229
-	-	1250	12	236	236	236
1000	10	1350	14	241	241	241
-	-	1600	17	249	249	249
1250	12	-	-	256	256	256
1350	14	2000	23	264	264	264
1600	17	-	-	281	281	281
2000	20	2500	25	301	301	301
2500	27	-	-	326	326	326
-	-	2000	22	276	276	276
-	-	2500	27	291	291	291
2500	25	3300	32	331	331	331
-	-	3600	36	346	346	346
3150	32	4000	40	361	361	361
3200	33	-	-	381	381	381
4000	40	5000	50	421	421	421
5000	51	-	-	471	471	471
-	-	6300	63	541	541	541

Right Side Feeder "T" - T Y R

Sample Order:

2500 A, Copper, Bolt-on, IP 55, 4 conductors

KXC 25504 - B - TYR

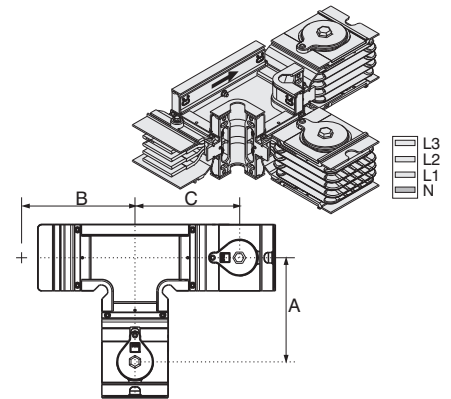

Left Side Feeder "T" - T Y L

Sample Order:

2500 A, Aluminium, Bolt-on, IP 55, 4 conductors

KXA 25504 - B - TYL

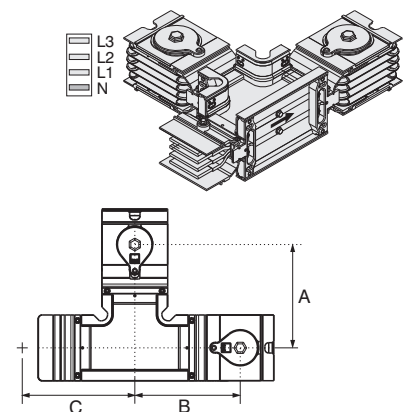

■ Please call us for non-standard components.
 ■ The dimensions given above are minimum values.

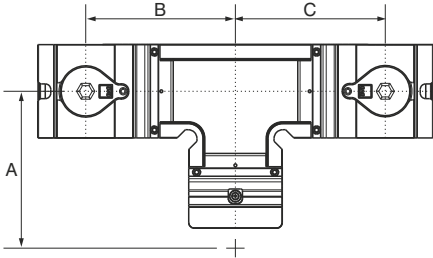
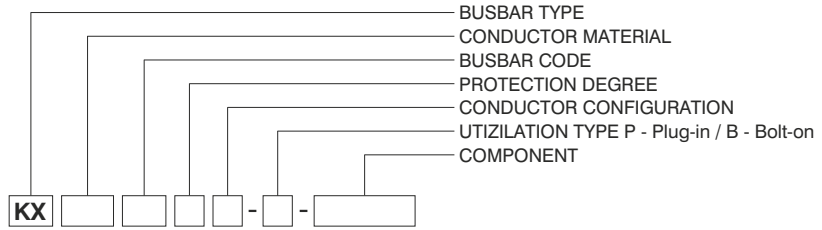

Central Feeder "T" - T O

Sample Order:
 3300 A, Copper, Bolt-on,
 IP 55, 4 conductors
KXC 32504 - B - TO

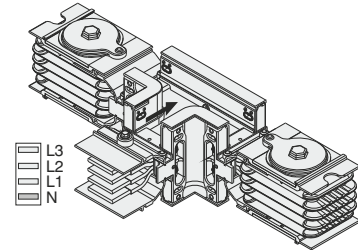

Vertical Expansion

Used for vertical applications in multi storey buildings.

- One vertical expansion unit is advised to be used at every floor between fixed support points.

Vertical Expansion - D D T

Sample Order:
 2000 A, Copper, Bolt-on, IP 55
 4 conductors
KXC 20504 - B - DDT

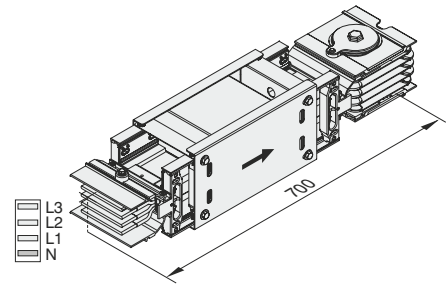

Horizontal Expansion

Used at every 40m in long horizontal straight lines and building expansion points.

Note:1) Horizontal expansion joint should be utilised if busbar line is crossing to adjacent through building expansion joints.

2) This module is used on the long busbar line (>75m.) where line is ended by end closure and is not fixed on the support rigidly.

3) Horizontal expansion joint has sufficient movement span of 54mm.

EAE requests to be consulted during design stage.

Horizontal Expansion - Y D T

Sample Order:
 2500 A, Aluminium, Bolt-on,
 IP 55, 4 conductors
KXA 25504 - B - YDT

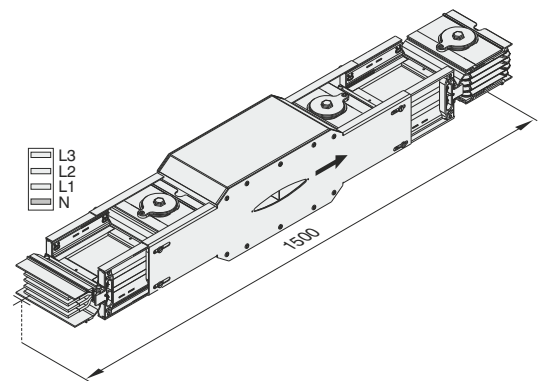

Attention!

The total length of the module should be adjusted to 1500 mm. after installation.

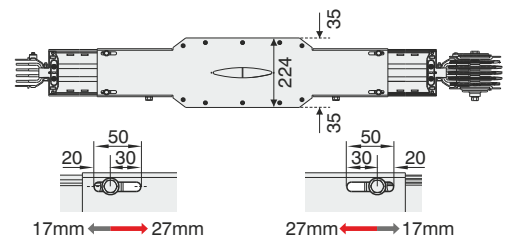

■ Please call us for non-standard components.

■ The dimensions given above are minimum values.

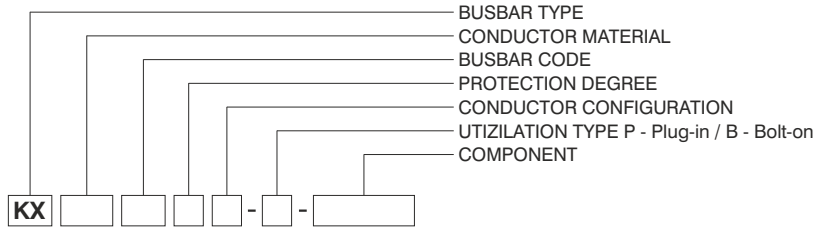

Phase Transposition Module

They used for transposition of phase sequence.

Phase Transposition Module - F D M

Sample Order:

2500 A, Aluminium, Bolt-on, IP 55, 4 conductors

KXA 25504 - B - FDM

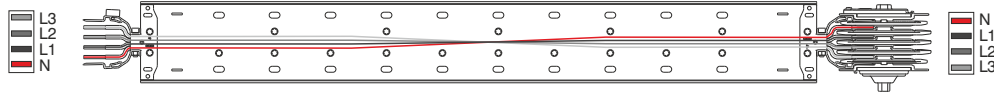
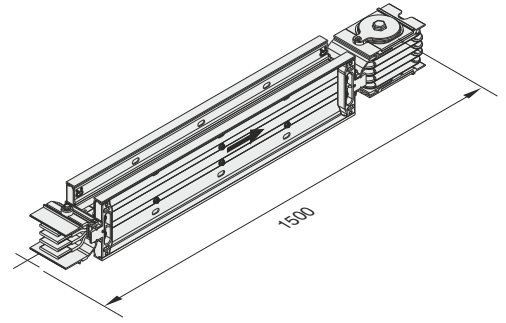

FDM Dimension Table

KXA - Al Conductor		KXC - Cu Conductor		A (mm)
Rated Current	Busbar Code	Rated Current	Busbar Code	
400	04	550	05	77,5
500	05	650	06	82,5
630	06	800	08	91
800	08	1000	10	106
-	-	1250	12	121
1000	10	1350	14	131
-	-	1600	17	146
1250	12	-	-	161
1350	14	2000	23	176
1600	17	-	-	211
2000	20	2500	25	251
2500	27	-	-	301

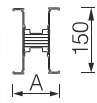

-	-	2000	22	202
-	-	2500	27	232
2500	25	3300	32	312
-	-	3600	36	342
3150	32	4000	40	372
3200	33	-	-	412
4000	40	5000	50	492
5000	51	-	-	592

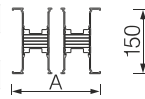

-	-	6300	63	732
---	---	------	----	-----

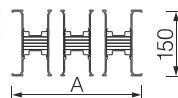

■ Please call us for non-standard components.

■ The dimensions given above are minimum values.

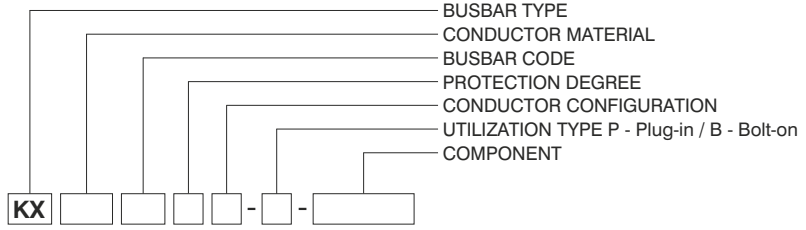

End Closer

Is used to close the end of busbar run.

Al Conductor		Cu Conductor		L1, L2, L3, N + Housing		04
				L1, L2, L3, N, ½ PE + Housing		07
				L1, L2, L3, N, PE + Housing		05
Rated Current	Busbar Code	Rated Current	Busbar Code	Dimensions (mm)	Order No	
400	04	550	05	6x25	3066129	
500	05	650	06	6x30	3066131	
630	06	800	08	6x40	3016698	
800	08	1000	10	6x55	3016699	
-	-	1250	12	6x70	3016700	
1000	10	1350	14	6x80	3016701	
-	-	1600	17	6x95	3085740	
1250	12	-	-	6x110	3016702	
1350	14	2000	23	6x125	3016703	
1600	17	-	-	6x160	3016705	
2000	20	2500	25	6x200	3016706	
2500	27	-	-	6x250	3016710	
-	-	2000	22	2(6x55)	3016707	
-	-	2500	27	2(6x70)	3127358	
2500	25	3300	32	2(6x110)	3016709	
-	-	3600	36	2(6x125)	3016711	
3150	32	4000	40	2(6x140)	3016712	
3200	33	-	-	2(6x160)	3016713	
4000	40	5000	50	2(6x200)	3113536	
5000	51	-	-	2(6x250)	3127359	
-	-	6300	63	3(6x200)	3113537	

Note: S10 or S11 modules should be used as end closer for the busbars with 03, 08, 09, 06 codes and for all IP67 products.

End Closer - S

Sample Order:

2000 A, Aluminium, 2500 A, Copper Bolt-on, IP 55, 4 / 4½ / 5 conductors

KX 205A / 255C - B - S

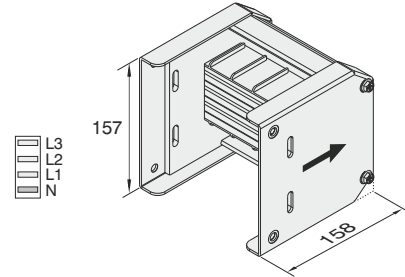

End Closer - S 1 0

Sample Order:

6300 A, Copper Bolt-on, IP 67, 3 conductors

KXC 63603 - B - S 1 0

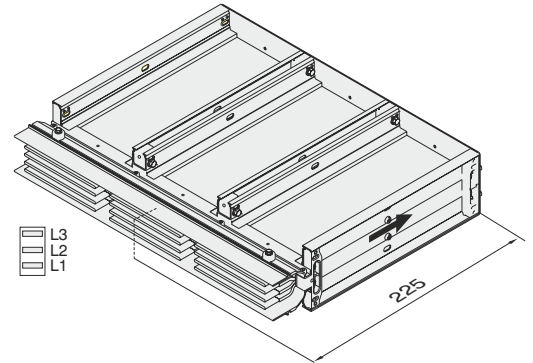

End Closer - S 1 1

Sample Order:

5000 A, Copper, Bolt-on, IP 67, 3 conductors

KXC 50603 - B - S 1 1

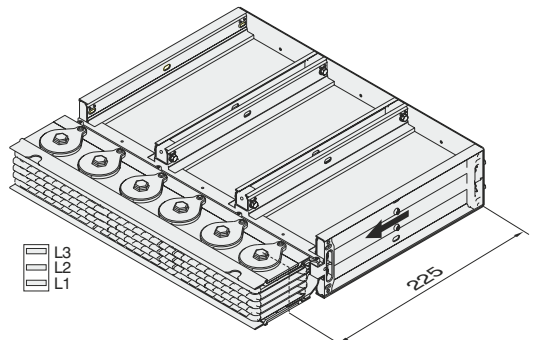

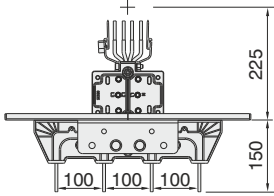
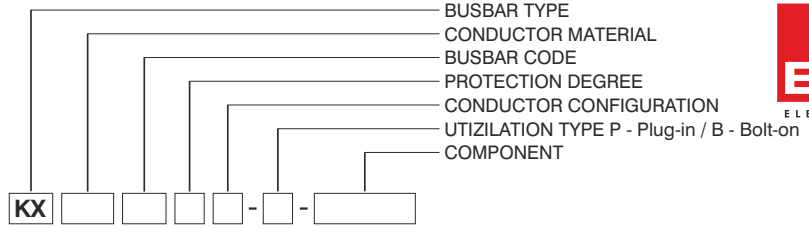

Panel Connection - P 1 0

Panel Feeder

Sample Order:

2500 A, Copper, Bolt-on, 4 conductors for Panel Feeder

KXC 25504 - B - P10

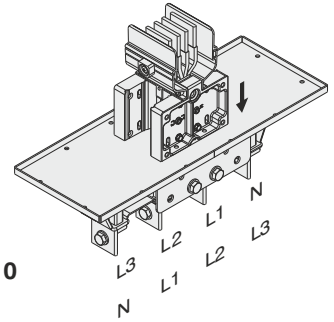

P10

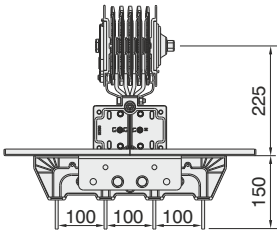

Panel Connection - P 1 1

Busbar Feeder

Sample Order:

2500 A, Copper, Bolt-on, 4 conductors for Busbar Feeder

KXC 25504 - B - P11

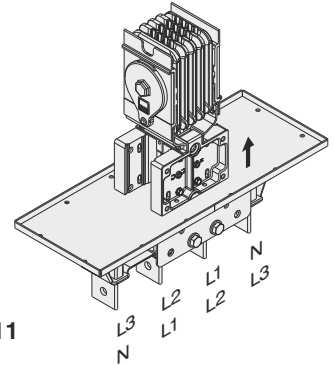

P11

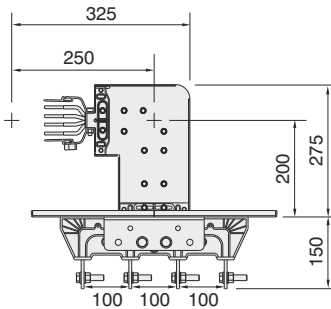

Upwards Panel Connection - P U 2 0

Panel Feeder

Sample Order:

3600 A, Copper, Bolt-on, 4 conductors for Panel Feeder

KXC 36504 - B - PU20

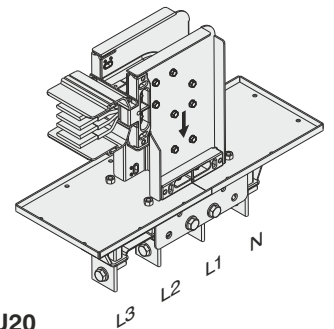

PU20

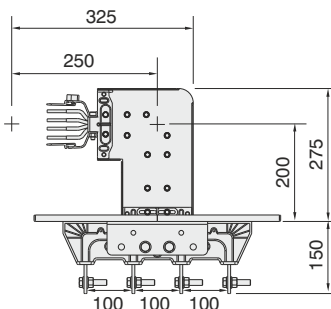

Downwards Panel Connection - P D 2 0

Panel Feeder

Sample Order:

4250 A, Copper, Bolt-on, 4 conductors for Panel Feeder

KXC 43504 - B - PD20

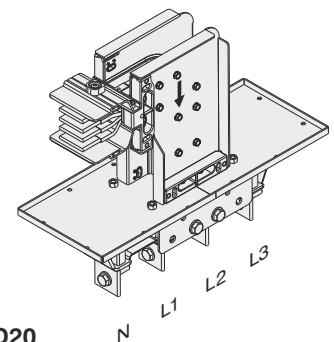

PD20

For connection dimensions please refer to tables on pages 23 and 24.

■ Distance between conductors can vary in ± 5 mm.

■ Please call us for non-standard components.

■ The dimensions given above are minimum values.

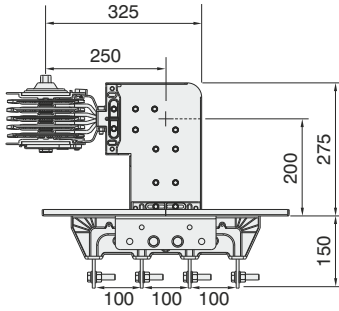
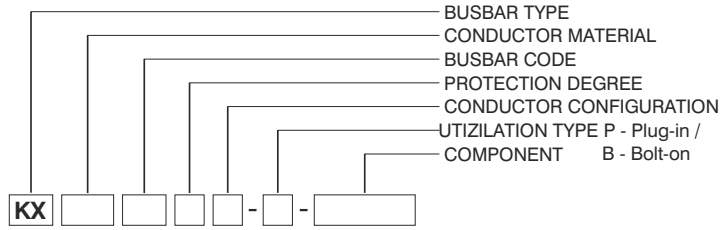

Upwards Busbar Connection - P U 2 1

Busbar Feeder

Sample Order:

3600 A, Copper, Bolt-on, 4 conductors for Busbar Feeder

KXC 36504 - B - PU21

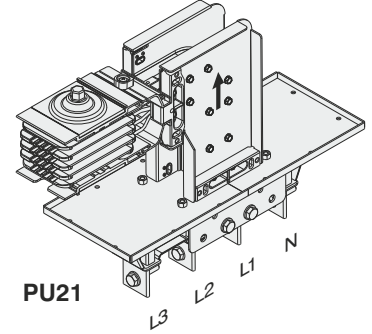

PU21

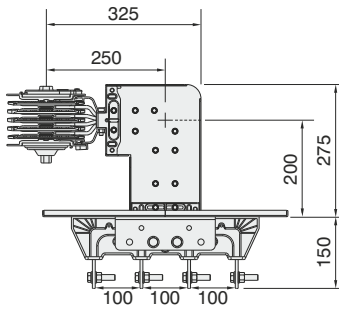

Downwards Busbar Connection - P D 2 1

Busbar Feeder

Sample Order:

4250 A, Copper, Bolt-on, 4 conductors for Busbar Feeder

KXC 43504 - B - PD21

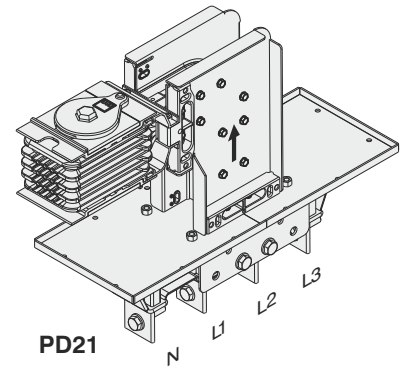

PD21

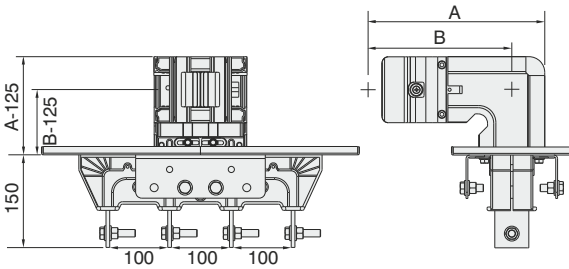

Right Panel Connection - P R 3 0

Panel Feeder

Sample Order:

2500 A, Copper, Bolt-on, 4 conductors for Panel Feeder

KXC 25504 - B - PR30

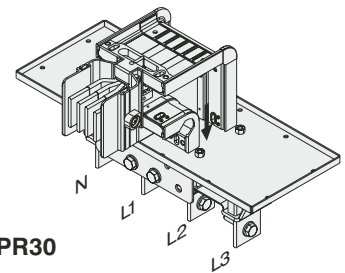

PR30

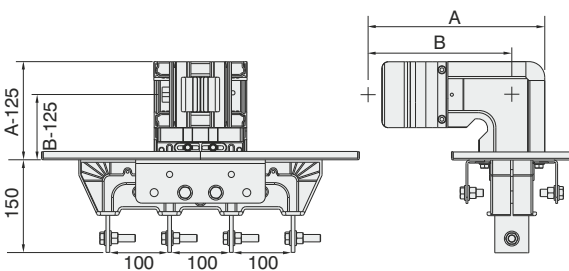

Left Panel Connection - P L 3 0

Panel Feeder

Sample Order:

2500 A, Copper, Bolt-on, 4 conductors for Panel Feeder

KXC 25504 - B - PL30

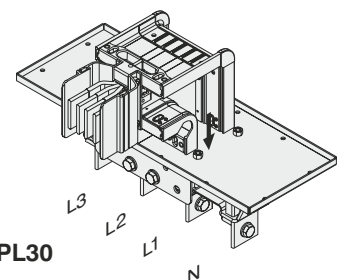

PL30

The "A" and "B" dimensions for PR30 and PL30 are the same dimensions as left and right elbows. Please refer to page 12 for the dimensions.

For connection dimensions please refer to tables on pages 23 and 24.

■ Distance between conductors can vary in ± 5 mm.

■ Please call us for non-standard components.

■ The dimensions given above are minimum values.

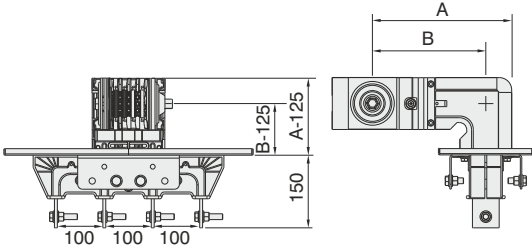
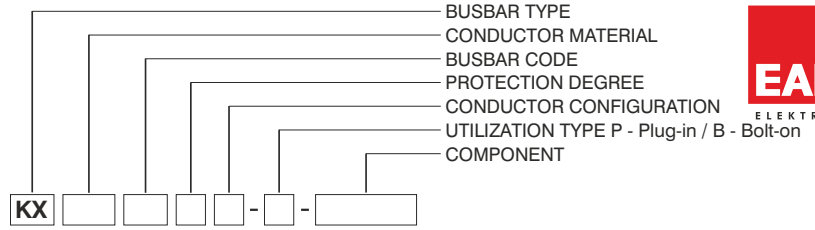

Right Panel Connection - PR 31

Busbar Feeder

Sample Order:

2500 A, Copper, Bolt-on, 4 conductors for Busbar Feeder

KXC 25504 - B - PR31

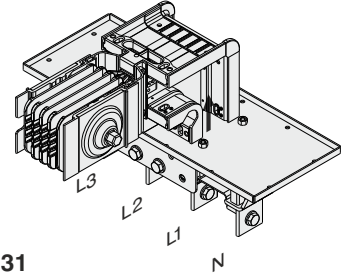

PR31

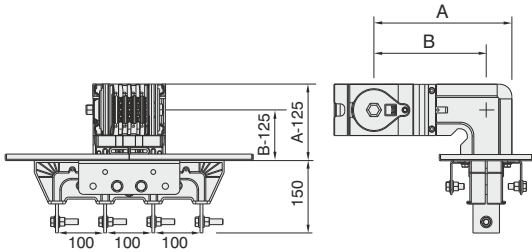

Left Panel Connection - PL 31

Busbar Feeder

Sample Order:

2500 A, Copper, Bolt-on, 4 conductors for Busbar Feeder

KXC 25504 - B - PL31

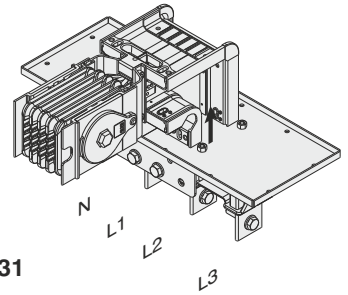

PL31

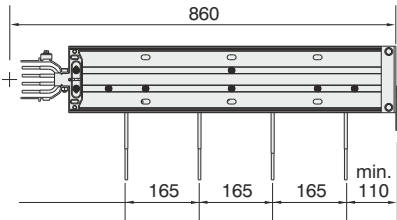

Panel Connection - P 4 0

Panel Feeder

Sample Order:

3300 A, Copper, Bolt-on, 4 conductors for Panel Feeder

KXC 32504 - B - P40

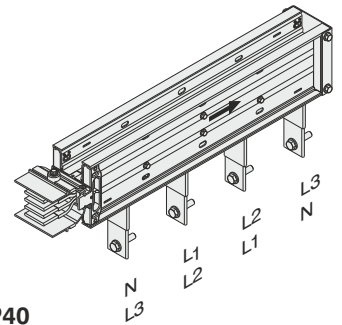

P40

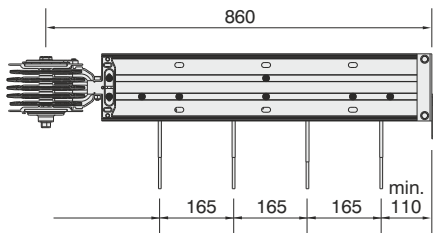

Panel Connection - P 4 1

Busbar Feeder

Sample Order:

3300 A, Copper, Bolt-on, 4 conductors for Busbar Feeder

KXC 32504 - B - P41

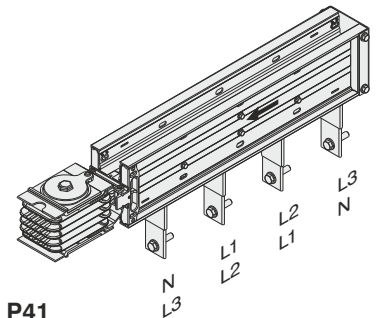

P41

The "A" and "B" dimensions for PR31 and PL31 are the same dimensions as left and right elbows. Please refer to page 12 for the dimensions.

For connection dimensions please refer to tables on pages 23 and 24.

■ Distance between conductors can vary in ± 5 mm.

■ The dimensions given above are minimum values.

■ Please call us for non-standard components.

Panel Connection Units

Panel Connection Units (P10,P11,PU20,PD20,PU21,PD21,PL30,PR30,PL31,PR31,P40,P41)

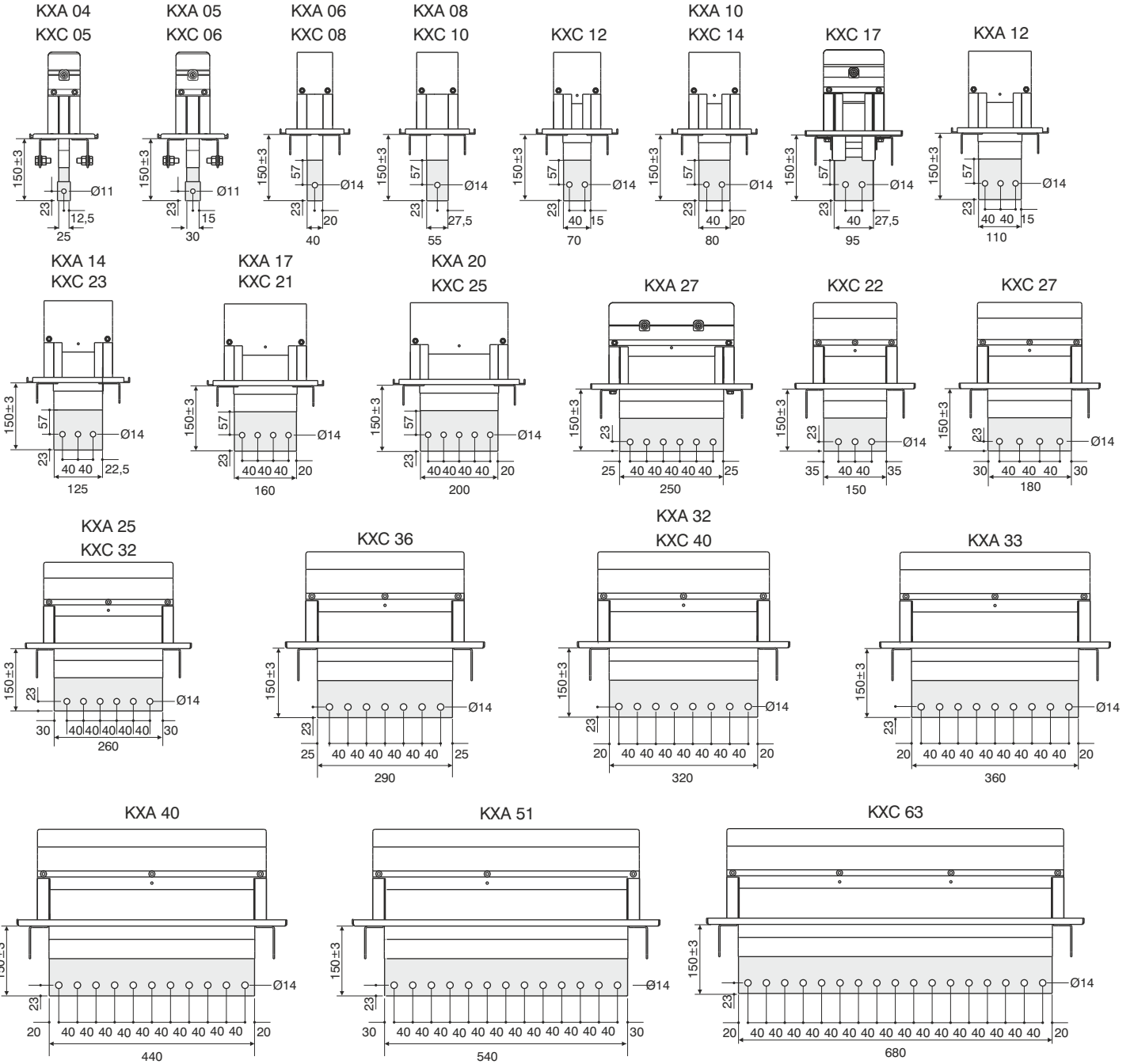

Sample Connection

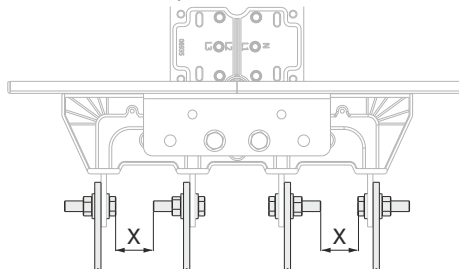

(Minimum X= 25 mm)

■ Please call us for non-standard components.

■ Distance between conductors can vary in ±5 mm.

■ The dimensions given above are minimum values.

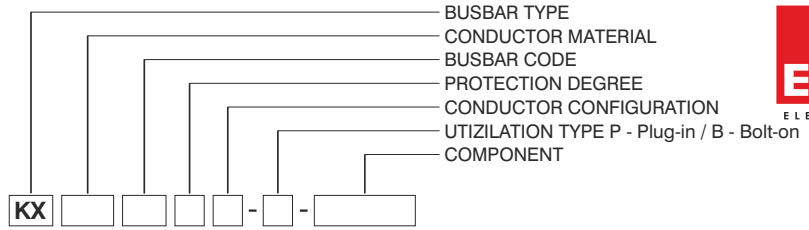

Flange Dimensions

Panel Connection Units are supplied with suitable flange as standard.

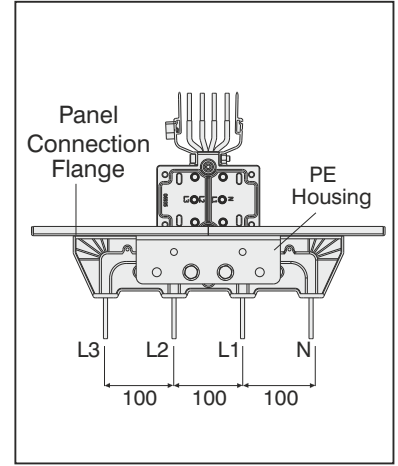
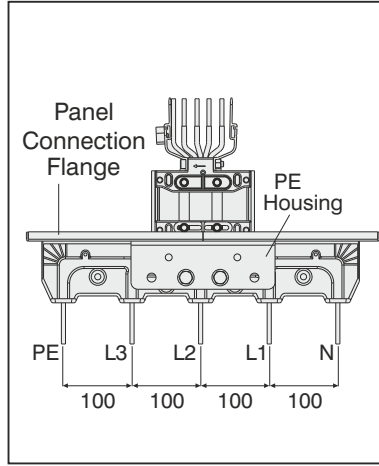
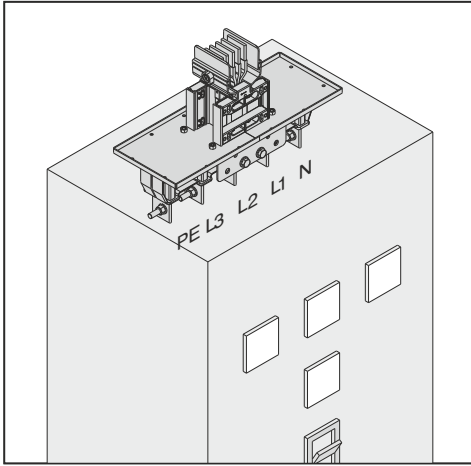

Opening on the panel board E-Line KX Panel Connection Busbar Flange

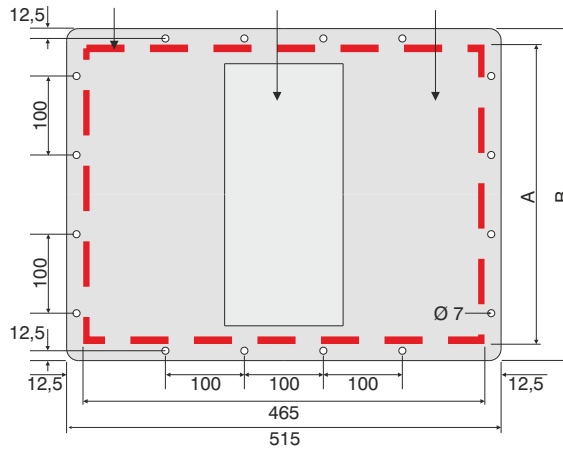

* Bolt and nut sets are supplied together with related product as per the quantities below.

Aluminium (Al)		Copper (Cu)		Conductor Size	A (mm)	B (mm)	Number of the holes along B length	* M6 Bolt/ Nut Set(pcs)
Rated Current	Busbar Code	Rated Current	Busbar Code					
400	04	550	05	6x25	120	165	2	12
500	05	650	06	6x30	125	170	2	12
630	06	800	08	6x40	135	180	2	12
800	08	1000	10	6x55	150	195	2	12
-	-	1250	12	6x70	165	210	2	12
1000	10	1350	14	6x80	175	220	2	12
-	-	1600	17	6x95	190	235	3	14
1250	12	-	-	6x110	205	250	3	14
1350	14	2000	23	6x125	220	265	3	14
1600	17	-	-	6x160	255	300	3	14
2000	20	2500	25	6x200	295	340	4	16
2500	27	-	-	6x250	345	390	4	16
-	-	2000	22	2(6x55)	245	290	3	14
-	-	2500	27	2(6x70)	275	320	3	14
2500	25	3300	32	2(6x110)	355	400	4	16
-	-	3600	36	2(6x125)	385	430	4	16
3150	32	4000	40	2(6x140)	415	460	5	18
3200	33	-	-	2(6x160)	455	500	5	18
4000	40	5000	50	2(6x200)	535	580	6	20
5000	51	-	-	2(6x250)	635	680	7	22
-	-	6300	63	3(6x200)	775	820	8	24

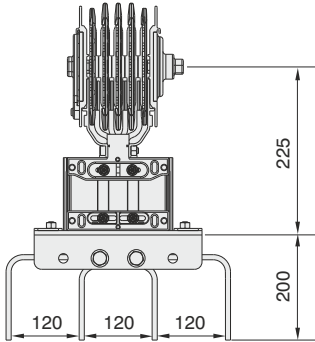
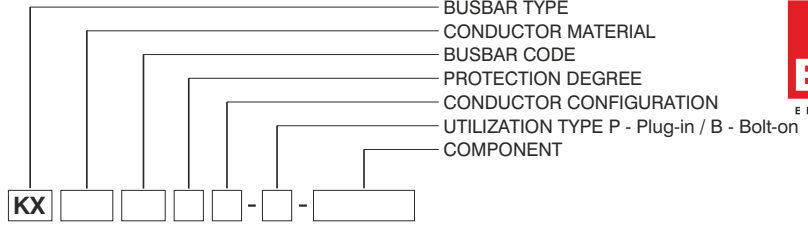

Transformer Connection - T R 1 1

Sample Order:

2500 A, Aluminium, Bolt-on, 4 conductors
KXA 25504 - B - TR11-120

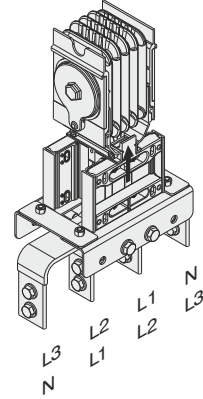

TR11

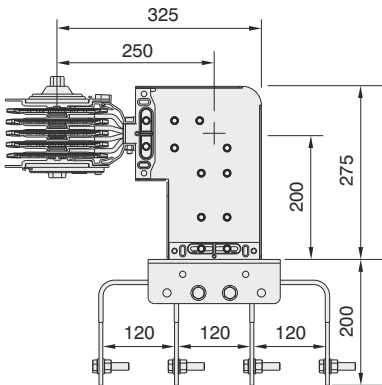

Upwards Transformer Connection - T U 2 1

Sample Order:

2500 A, Copper, Bolt-on, 4 conductors
KXC 25504 - B - TU21-120

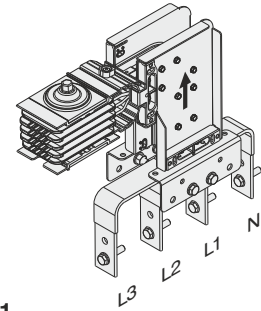

TU21

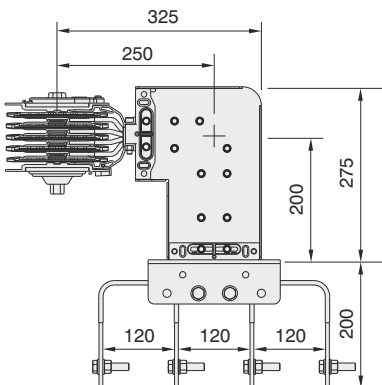

Downwards Transformer Connection - T D 2 1

Sample Order:

2500 A, Aluminium, Bolt-on, 4 conductors
KXA 25504 - B - TD21-120

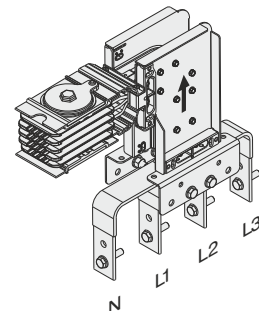

TD21

For connection dimensions please refer to tables on pages 28 and 29.

- Distance between conductors can vary in ± 5 mm.
- Please call us for non-standard components.
- The dimensions given above are minimum values.

BUSBAR TYPE
 CONDUCTOR MATERIAL
 BUSBAR CODE
 PROTECTION DEGREE
 CONDUCTOR CONFIGURATION
 UTILIZATION TYPE P - Plug-in / B - Bolt-on
 COMPONENT

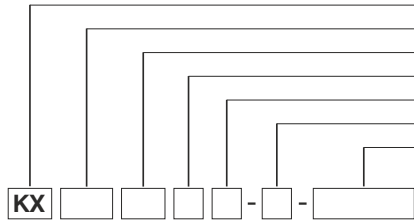

For transformer and panel connection applications EAE design and planning department can prepare your projects upon request.

For the design, the following information is required;

- Plan of transformer and panel board room, heights.
- Transformer dimensions, distance between bushings.

For connection dimensions please refer to tables on page 28.

Flexibles are used for

- Transformer - busbar,
- Panel - busbar connections.

Transformer Connection - T R 3 1

Sample Order:

2500 A, Copper, Bolt-on, 4 conductors

KXC 25504 - B - TR31

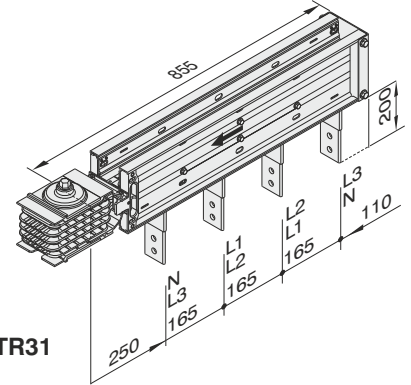

TR31

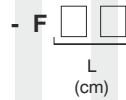

Flexibles

Sample Order:

800 A, Aluminium

KXA 0800 - F40

B=.....mm
 X=.....mm
 Y=.....mm
 Z=.....mm
 ø=.....mm

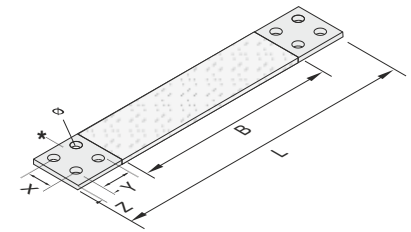

- This side is punched according to the needs of the customer.

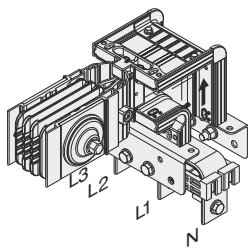

TR51

Right Transformer Connection - T R 5 1

Sample Order:

2500 A, Copper, Bolt-on, 4 conductors

KXC 25504 - B - TR51

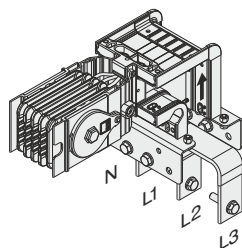
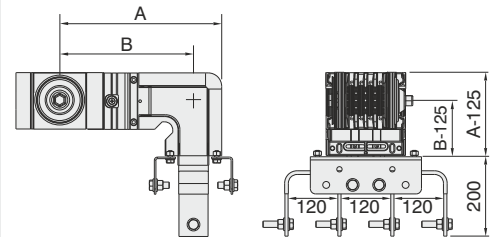

TL51

Left Transformer Connection - T L 5 1

Sample Order:

2500 A, Aluminium, Bolt-on, 4 conductors

KXA 25504 - B - TL51

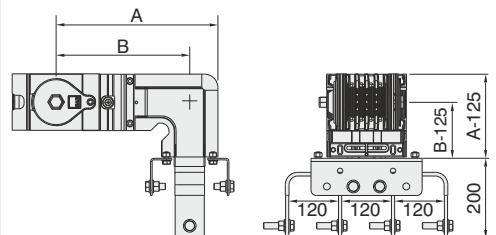

■ Distance between conductors can vary in ± 5 mm.

■ Please call us for non-standard components.

■ The dimensions given above are minimum values.

BUSBAR TYPE
 CONDUCTOR MATERIAL
 BUSBAR CODE
 PROTECTION DEGREE
 CONDUCTOR CONFIGURATION
 UTILIZATION TYPE P - Plug-in / B - Bolt-on
 COMPONENT



Transformer Connection - T R 4 1

Sample Order:

2500 A, Copper, Bolt-on, 4 conductors

KXC 25504 - B - TR41

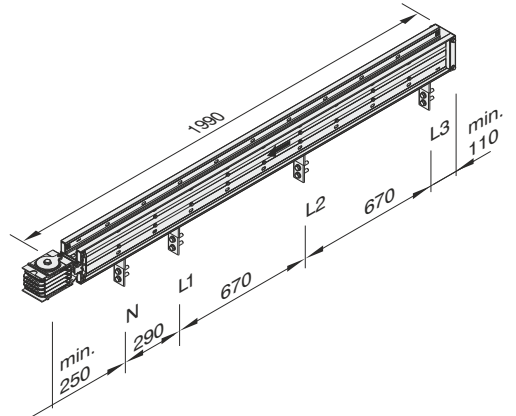

TR41

Transformer Connection - T R 6 1

Sample Order:

3600 A, Copper, Bolt-on, 4 conductors

KXC 36504 - B - TR61

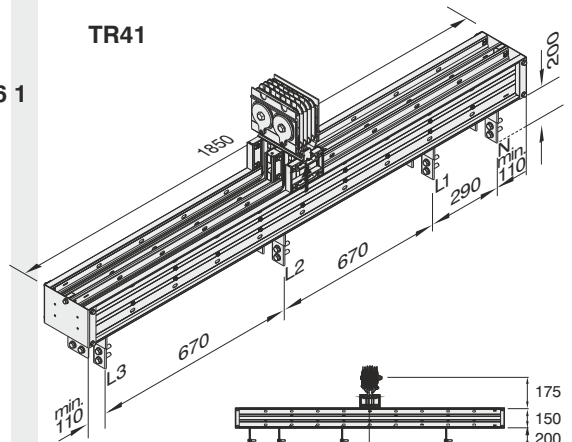

TR61

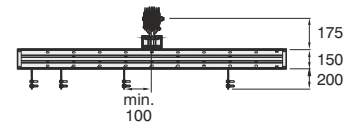

Transformer Connection - T R 7 1

Sample Order:

4000 A, Copper, Bolt-on, 4 conductors

KXC 40504 - B - TR71

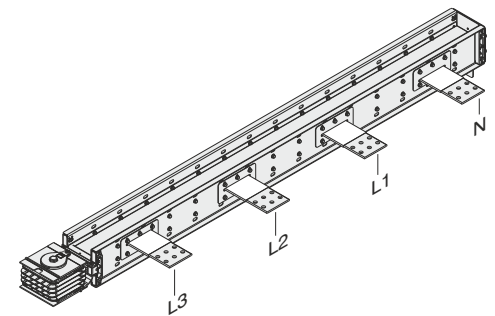

TR71

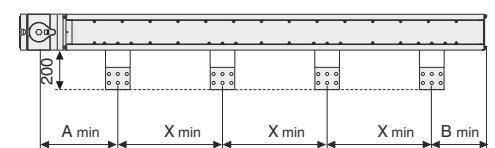
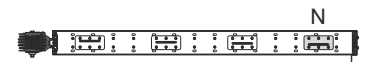

For transformer and panel connection applications EAE design and planning department can prepare your projects upon request.

For the design, the following information is required;

- Plan of transformer and panel board room, heights.
- Transformer dimensions, distance between bushings.

A and B dimensions of TR51 and TL51 are same as left and right elbows.

Please refer to page 12 for the dimensions.

For connection dimensions please refer to tables on page 28.

TR71 Dimension Table

KXA - Al Conductor		KXC - Cu Conductor		Conductor	A min (mm)	B min (mm)	X min (mm)
Rated Current	Busbar Code	Rated Current	Busbar Code				
400	04	550	05	6x25	263	123	85
500	05	650	06	6x30	265	125	90
630	06	800	08	6x40	270	130	100
800	08	1000	10	6x55	278	138	115
-	-	1250	12	6x70	285	145	130
1000	10	1350	14	6x80	290	150	140
-	-	1600	17	6x95	298	158	155
1250	12	-	-	6x110	305	165	170
1350	14	2000	23	6x125	313	173	185
1600	17	-	-	6x160	330	190	220
2000	20	2500	25	6x200	350	210	260
2500	27	-	-	6x250	375	235	310
-	-	2000	22	2(6x55)	278	138	115
-	-	2500	27	2(6x70)	285	145	130
2500	25	3300	32	2(6x110)	305	165	170
-	-	3600	36	2(6x125)	313	173	185
3150	32	4000	40	2(6x140)	320	180	200
3200	33	-	-	2(6x160)	330	190	220
4000	40	5000	50	2(6x200)	350	210	260
5000	51	-	-	2(6x250)	375	235	310

- Distance between conductors can vary in ± 5 mm.
- Please call us for non-standard components.
- The dimensions given above are minimum values.

Transformer Connection Units

Transformer Connection Units (TR31, TR41, TR61)

Note: No flange supplied with transformer connection units.

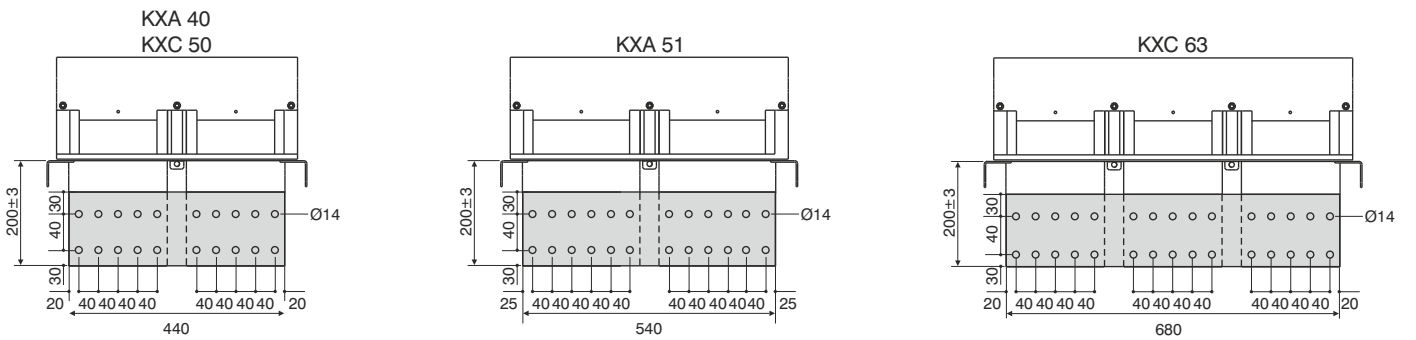
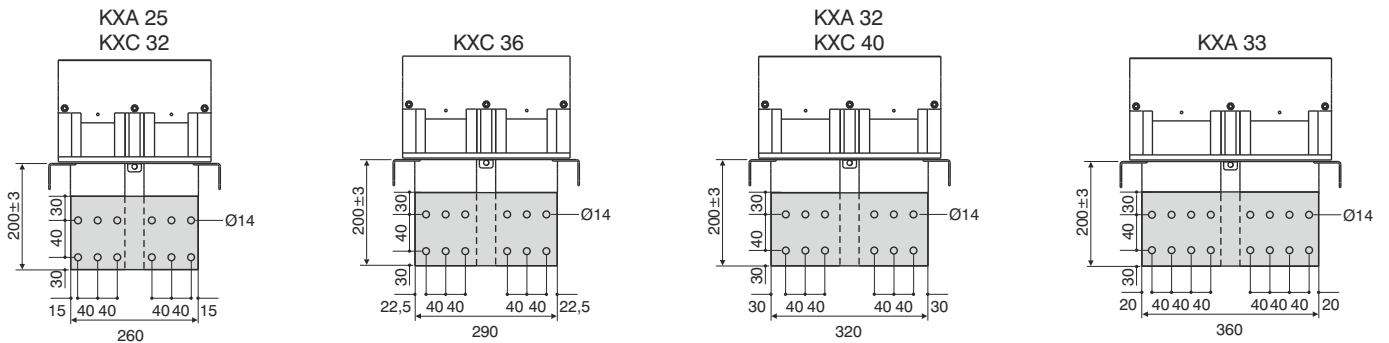
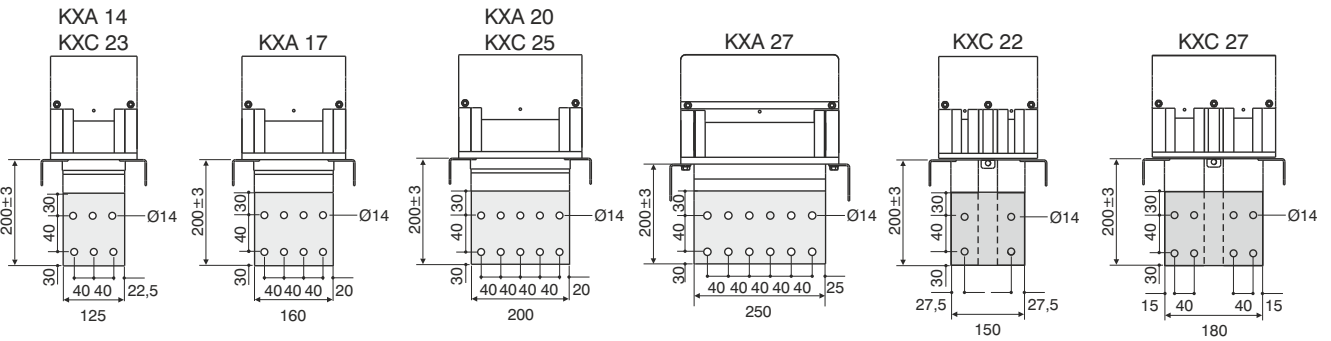
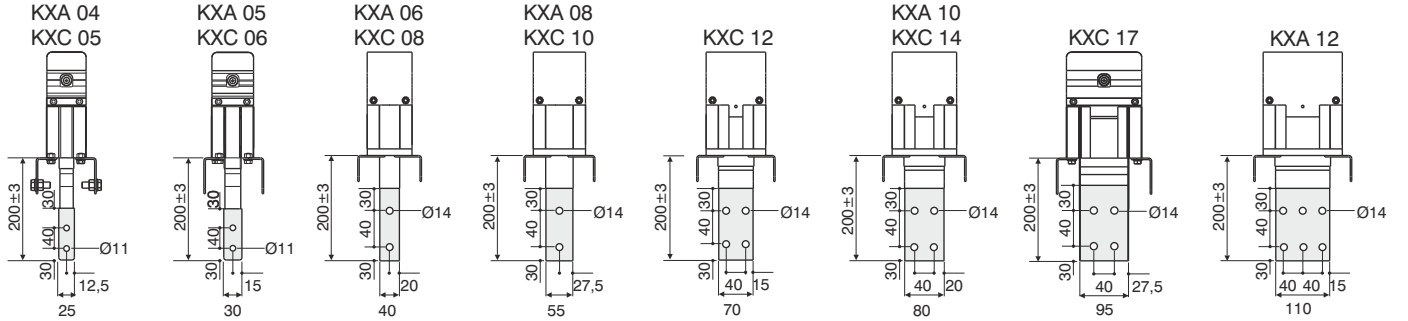

Sample Connection

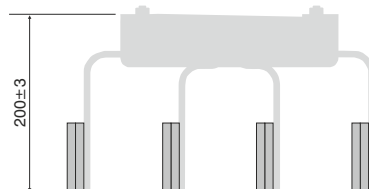

■ Please call us for non-standard components.

■ Distance between conductors can vary in ± 5 mm.

■ The dimensions given above are minimum values.

Transformer Connection Units

Transformer Connection Units (TR11, TU21, TD21, TR51, TL51)

Note: No flange supplied with transformer connection units.

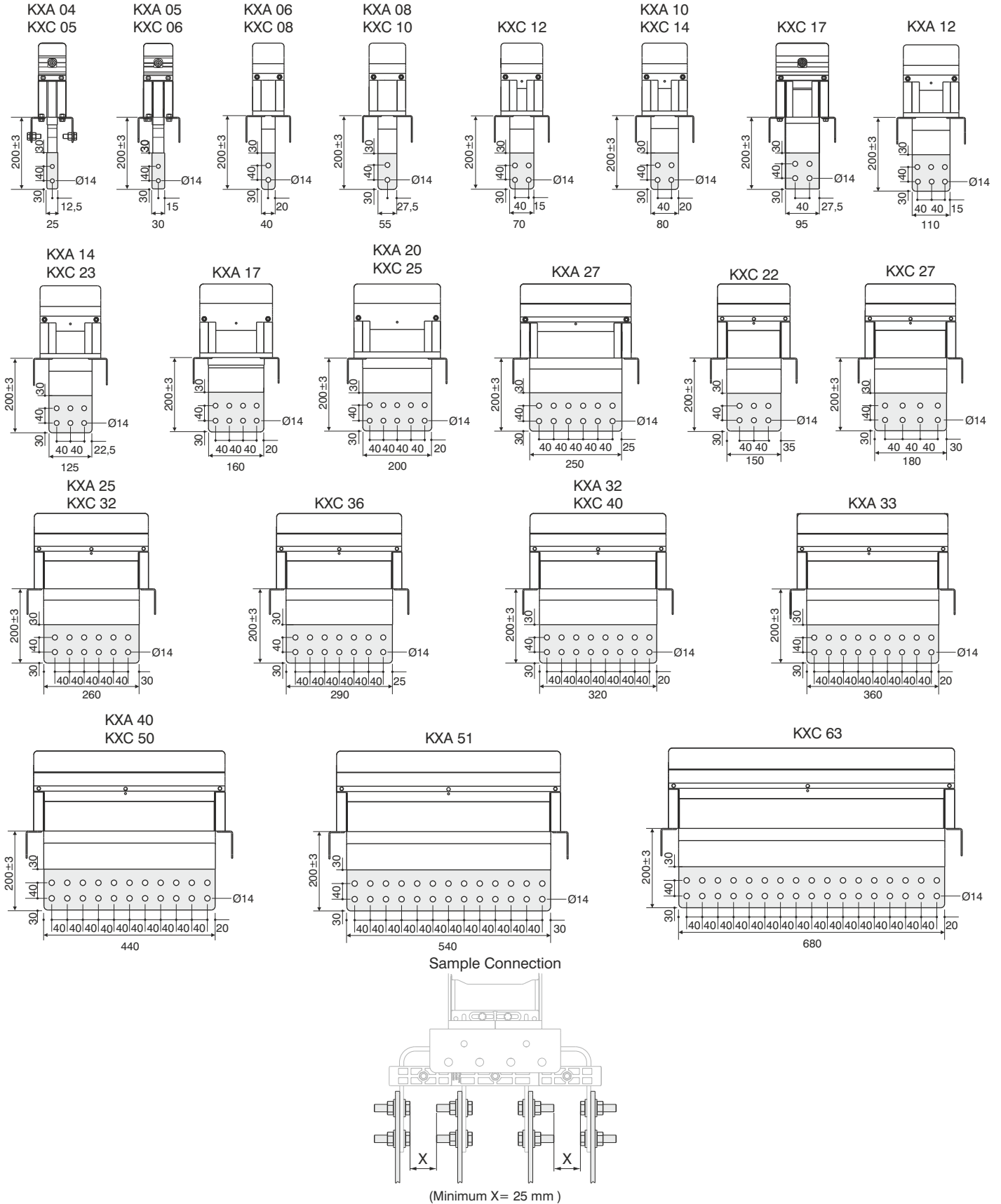

■ Please call us for non-standard components.

■ Distance between conductors can vary in ±5 mm.

■ The dimensions given above are minimum values.

Easy Installation System of Tap-off Boxes

The patented hinge system is designed to allow the installation of plug-in tap-off boxes simply and easily.

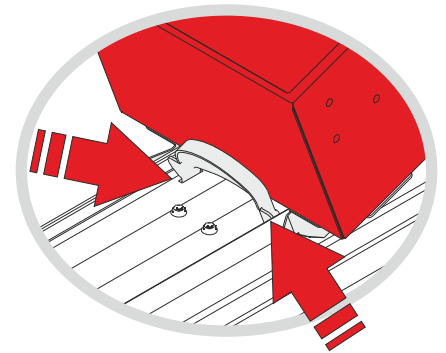
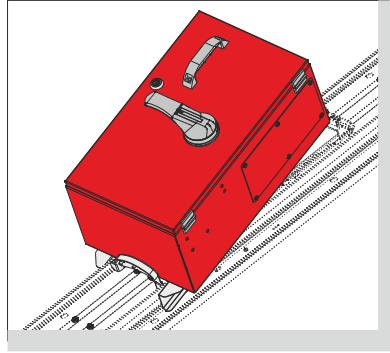
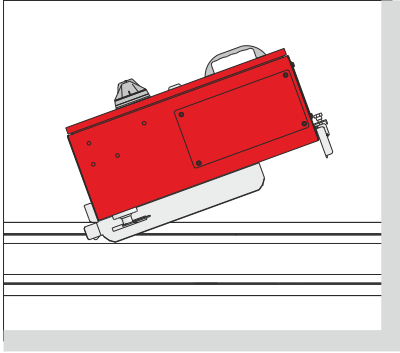

Fixing System of Tap-off Boxes to Busbars

Hook system, which is used for fixing of tap-off boxes on busbars.

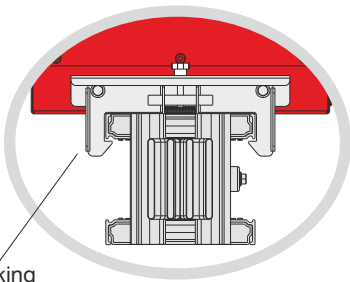
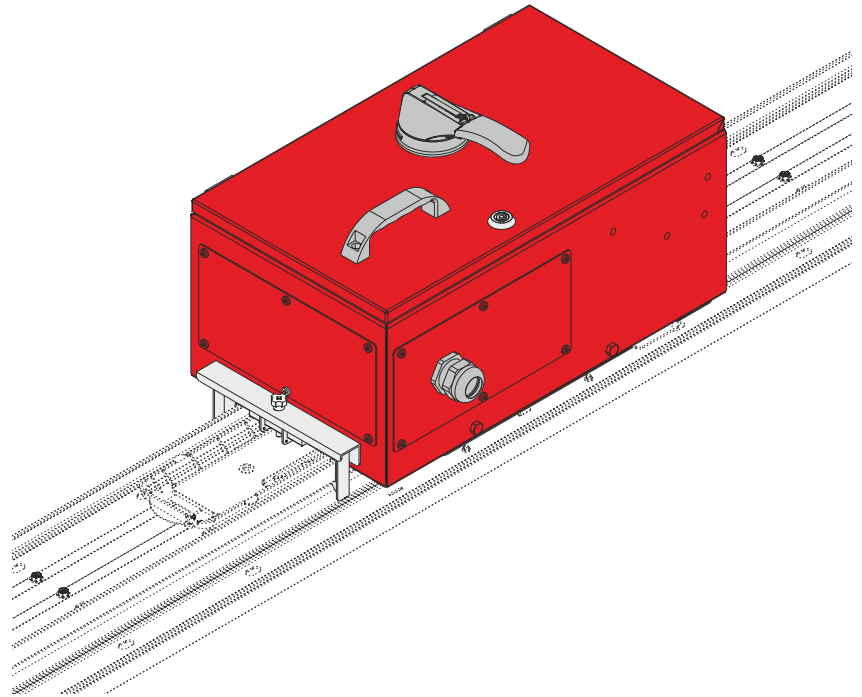
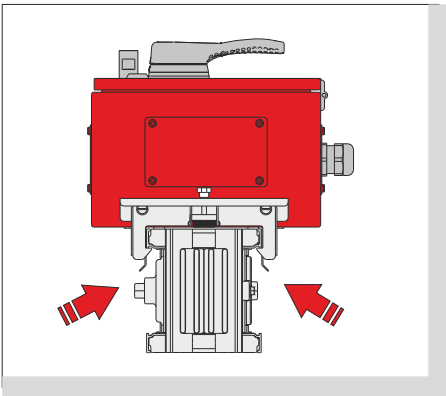

Locking Point

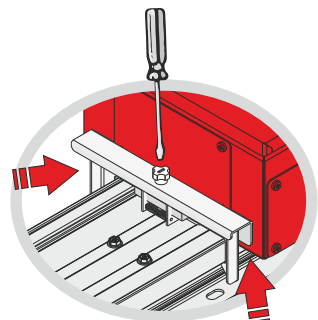

Universal Tap-off Boxes

Tap off boxes can be equipped with any brand of switches, circuit breakers and etc. Please inform EAE the type and brand of choosen MCCB, when ordering.

Side Opening Box Lids

A new generation of tap-off box with side opening lids enables easier connection to protective devices and maintenance.

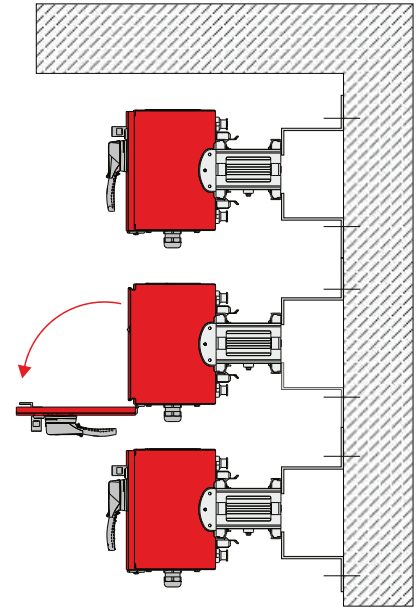
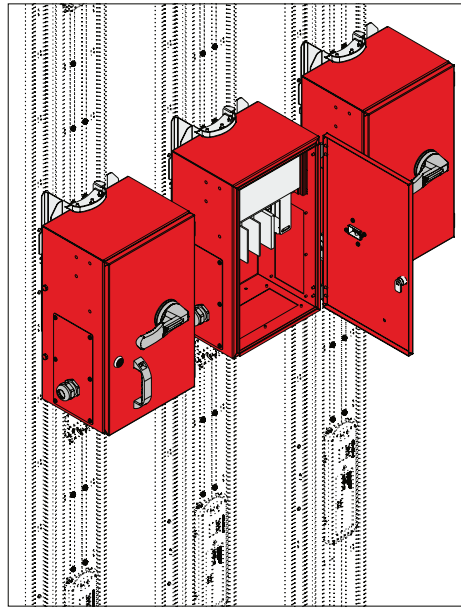

Bolt-on Tap-off Boxes

- Bolt-on tap-off boxes are designed to be installed at the joints without removing the joint block.
- The range of tap off boxes from 160A upto 1.000A.
- Busbar run must be de-energized before installing bolt-on tap-off boxes.

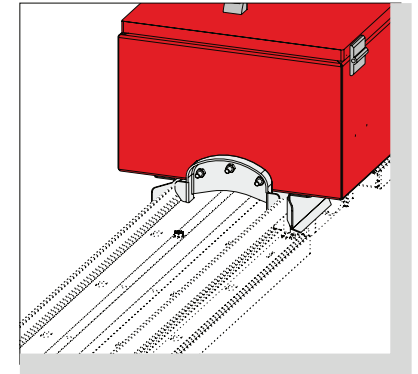
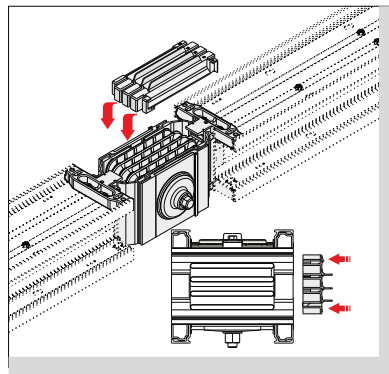

Effective Gasket

- Protection from dust and humidity due to effective gasket system.
- High IP Protection due to special forming.

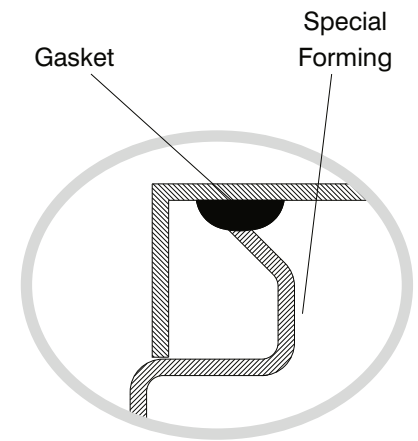
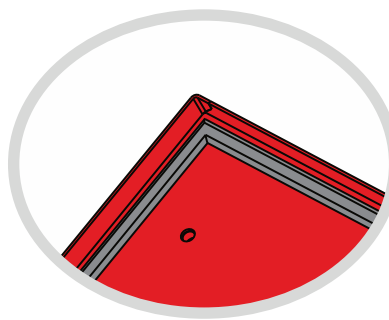
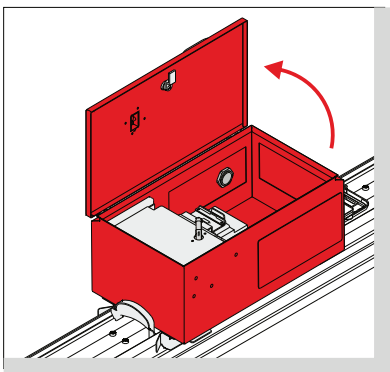

▶▶ Tap-off Boxes with Fused Switches (Bolt-on-KXB)

Cable Gland Plates

Mat.	Cable Gland Type	Order Code	Inner Diameter (mm)
Sheet	----	RP0	
Sheet	M32	RP1	25
Sheet	M40	RP2	32
Sheet	Special	RP3	63
AL	2xSpecial	RP4	63
AL	4xM25	RP5	18
AL	4xM32	RP6	25
AL	4xM40	RP7	32
AL	8xM32	RP8	25

Notes:

EAE Bolt-on Tap Off Boxes are secured with an interlocking mechanism. This protects against attaching them to or removing them from the busbar in the "ON" position. When in the "OFF" position they are safe to attach to or remove from the busbar.

- Tap off boxes shall not be used empty. Fused switches, MCCBs or similar protection devices must be installed into tap-off boxes before they are installed to the busbar runs.

Tap-off Boxes	A (mm)	B (mm)	C (mm)	D (mm)	Fuse Size	Standard Gland
KXB 16	750	380	240	265	NH 1	RP2
KXB 25	750	380	240	265	NH 1	RP3
KXB 40	850	420	260	265	NH 3	RP4
KXB 63	850	420	260	265	NH 3	RP4

Tap-off boxes can be equipped with any brand of switches, circuit breakers and etc.

Please call us for non-standard tap-off boxes and detailed information.

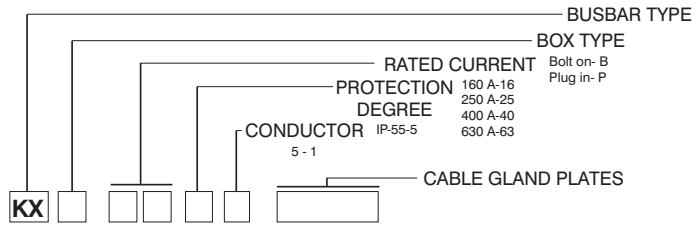

Bolt-on Tap-off Boxes

KX B 1 6 5 1
KX B 2 5 5 1
KX B 4 0 5 1
KX B 6 3 5 1

Sample Order:

Bolt-on / 630 A / IP-55 / 5 conductors

KXB 6351

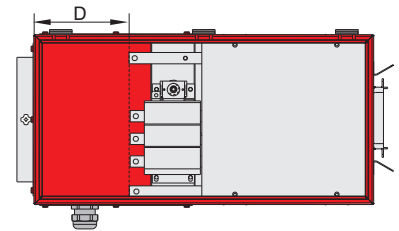
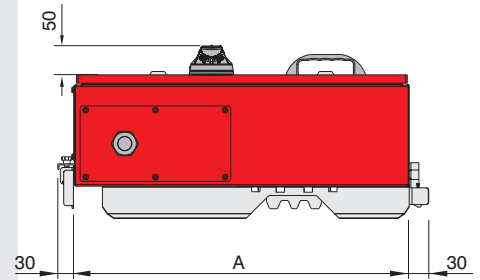
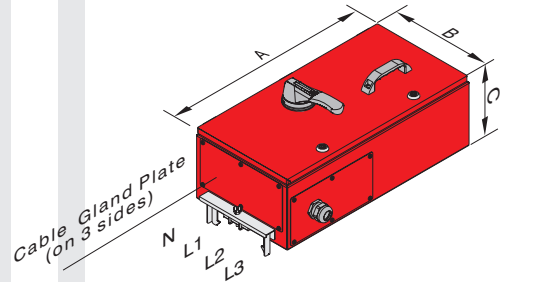

Bolt-on tap-off box can not be used on the joints of mentioned ranges of busbars.

KXA - Al Conductor		KXC - Cu Conductor		Bolt-on Tap-off Box
Rated Current	Busbar Code	Rated Current	Busbar Code	
400	04	550	05	x
500	05	650	06	x
630	06	800	08	x

Gland Type	Max. External Diameter of Cable Cross-section
M25	Ø 18
M32	Ø 26
M40	Ø 33
M50	Ø 39
M63	Ø 45
Special for EAE	Ø 60

■ The dimensions given above are minimum values.

▶▶ Tap-off Boxes with Fused Switches (Plug-in-KXP)

Cable Gland Plates

Mat. Sheet	Cable Gland Type	Order Code	Inner Diameter (mm)
Sheet	M32	RP1	25
Sheet	M40	RP2	32
Sheet	Special	RP3	63
AL	2xSpecial	RP4	63
AL	4xM25	RP5	18
AL	4xM32	RP6	25
AL	4xM40	RP7	32
AL	8xM32	RP8	25

Notes:

EAE Plug-in Tap Off Boxes are secured with an interlocking mechanism. This protects against attaching them to or removing them from the busbar in the "ON" position. When in the "OFF" position they are safe to attach to or remove from the busbar.

- Tap off boxes shall not be used empty. Fused switches, MCCBs or similar protection devices must be installed into tap-off boxes before they are installed to the busbar runs.

Tap-off Boxes	A (mm)	B (mm)	C (mm)	D (mm)	Fuse Size	Standard Gland
KXP 16	520	300	210	140	NH00	RP2
KXP 25	670	380	270	290	NH 1	RP3
KXP 40	750	420	300	285	NH 3	RP4
KXP 63	750	420	300	285	NH 3	RP4

Tap-off boxes can be equipped with any brand of switches, circuit breakers and etc.

Please call us for non-standard tap-off boxes and detailed information.

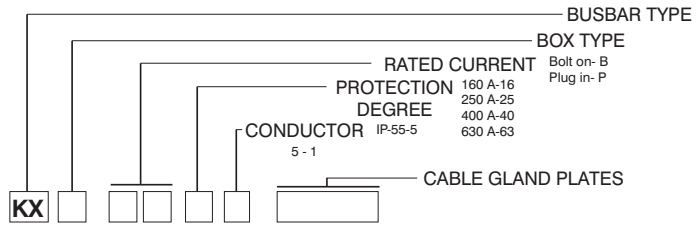

Plug-in Tap-off Boxes

- KX P 1 6 5 1**
- KX P 2 5 5 1**
- KX P 4 0 5 1**
- KX P 6 3 5 1**

Sample Order:

Plug-in / 630 A / IP-55 / 5 conductors

KXP 6351

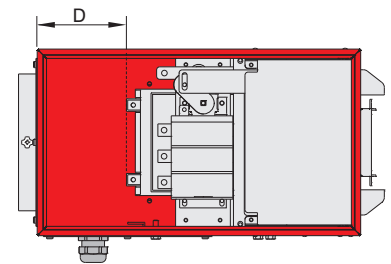
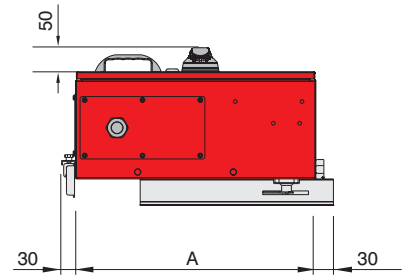
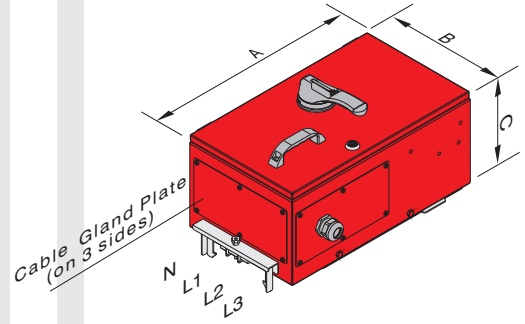

Gland Type	Max. External Diameter of Cable Cross-section
M25	Ø 18
M32	Ø 26
M40	Ø 33
M50	Ø 39
M63	Ø 45
Special for EAE	Ø 60

■ The dimensions given above are minimum values.

▶▶ Tap-off Boxes for MCCB's (KXB)

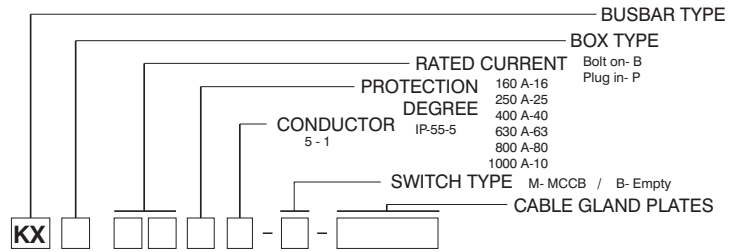

Cable Gland Plates

Mat.	Cable Gland Type	Order Code	Inner Diameter (mm)
Sheet	----	RP0	----
Sheet	M32	RP1	25
Sheet	M40	RP2	32
Sheet	Special	RP3	63
AL	2xSpecial	RP4	63
AL	4xM25	RP5	18
AL	4xM32	RP6	25
AL	4xM40	RP7	32
AL	8xM32	RP8	25
AL	3xSpecial	RP9	63

Bolt-on Tap-off Boxes

- KX B 1 6 5 1 - B
- KX B 2 5 5 1 - B
- KX B 4 0 5 1 - B
- KX B 6 3 5 1 - B
- KX B 1 6 5 1 - M
- KX B 2 5 5 1 - M
- KX B 4 0 5 1 - M
- KX B 6 3 5 1 - M

Sample Order:

Bolt-on / 630 A / IP-55 / 5 conductors, empty tap-off box

KXB 6351 - B

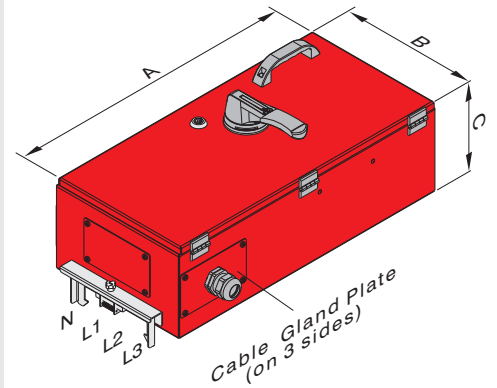

- KX B 8 0 5 1 - B
- KX B 1 0 5 1 - B
- KX B 8 0 5 1 - M
- KX B 1 0 5 1 - M

Sample Order:

Bolt-on / 800 A / IP-55 / 5 conductors, empty tap-off box

KXB 8051 - B

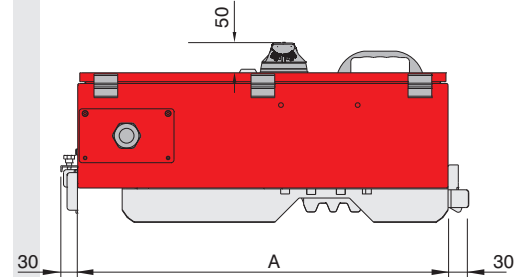

Special Cable Gland Plates

Mat.	Cable Gland Type	Order Code	Inner Diameter (mm)
Sheet	----	RPK0	----
Sheet	M25	RPK1	18
Sheet	M32	RPK2	25
Sheet	M40	RPK3	32
Sheet	1xSpecial	RPK4	63

Bolt-on tap-off box can not be used on the joints of mentioned ranges of busbars.

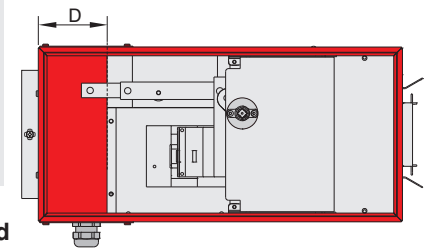

Tap-off Boxes	A (mm)	B (mm)	C (mm)	*D (mm)	Standard Gland
KXB 16	650	300	220	130	RPK3
KXB 25	650	300	220	130	RPK4
KXB 40	800	300	220	210	RP4
KXB 63	800	300	220	210	RP4
KXB 80	1100	450	275	385	RP9
KXB 10	1100	450	275	385	RP9

KXA - Al Conductor		KXC - Cu Conductor		Bolt-on Tap-off Box
Rated Current	Busbar Code	Rated Current	Busbar Code	
400	04	550	05	x
500	05	650	06	x
630	06	800	08	x

Gland Type	Max. External Diameter of Cable Cross-section
M25	Ø 18
M32	Ø 26
M40	Ø 33
M50	Ø 39
M63	Ø 45
Special for EAE	Ø 60

* D value varies as per the used switch.

*** Tap-off boxes can be equipped with any brand of MCCB's.**

Please call us for non-standard tap-off boxes.

■ The dimensions given above are minimum values.

▶▶ Tap-off Boxes for MCCB's (KXP)

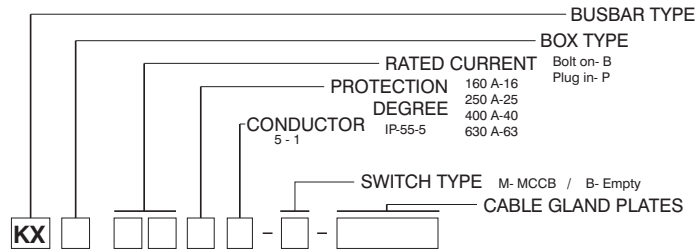

Cable Gland Plates

Mat.	Cable Gland Type	Order Code	Inner Diameter (mm)
Sheet	----	RP0	----
Sheet	M32	RP1	25
Sheet	M40	RP2	32
Sheet	Special	RP3	63
AL	2xSpecial	RP4	63
AL	4xM25	RP5	18
AL	4xM32	RP6	25
AL	4xM40	RP7	32
AL	8xM32	RP8	25

Plug-in Tap-off Boxes

- KX P 1 6 5 1 - B1
- KX P 2 5 5 1 - B1
- KX P 4 0 5 1 - B1
- KX P 6 3 5 1 - B1

- KX P 1 6 5 1 - M1
- KX P 2 5 5 1 - M1
- KX P 4 0 5 1 - M1
- KX P 6 3 5 1 - M1

Sample Order:

Plug-in / 400 A / IP-55 / 5 conductors, empty tap-off box

KXP 4051 - B1

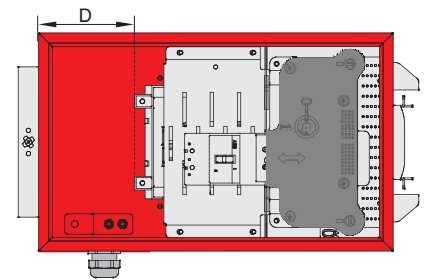
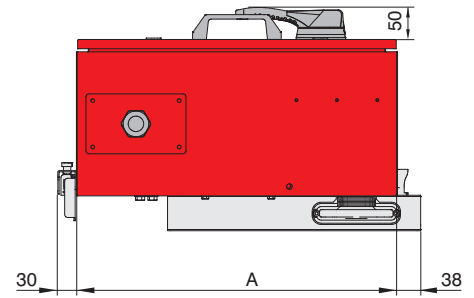
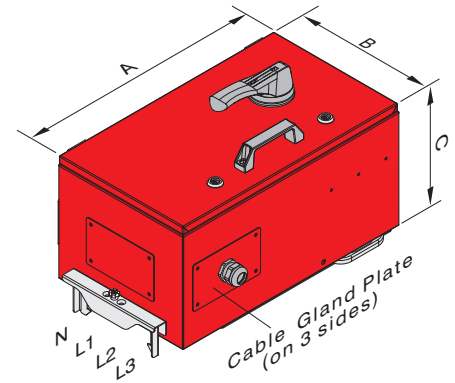

Special Cable Gland Plates

Mat.	Cable Gland Type	Order Code	Inner Diameter (mm)
Sheet	----	RPK0	----
Sheet	M25	RPK1	18
Sheet	M32	RPK2	25
Sheet	M40	RPK3	32
Sheet	1xSpecial	RPK4	63

Tap-off Boxes	A (mm)	B (mm)	C (mm)	*D (mm)	Standard Gland
KXP 16	520	320	250	150	RPK3
KXP 25	520	320	250	150	RPK4
KXP 40	700	320	250	255	RP4
KXP 63	700	320	250	255	RP4

* D value varies as per the used switch.

*** Tap-off boxes can be equipped with any brand of MCCB's.**

Gland Type	Max. External Diameter of Cable Cross-section
M25	Ø 18
M32	Ø 26
M40	Ø 33
M50	Ø 39
M63	Ø 45
Special for EAE	Ø 60

Please call us for non-standard tap-off boxes.

The dimensions given above are minimum values.

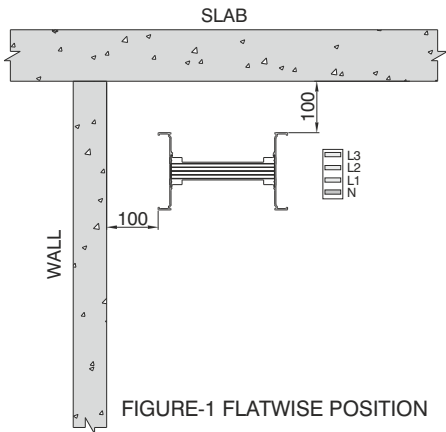

FIGURE-1 FLATWISE POSITION

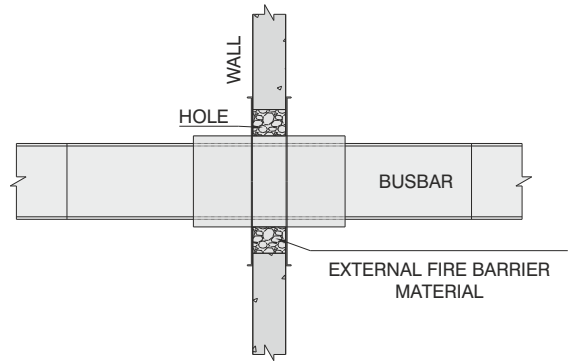

FIGURE-5 SAMPLE WALL CROSSING WITH FIRE BARRIER

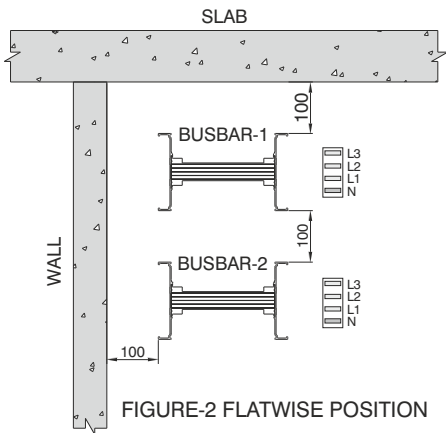

FIGURE-2 FLATWISE POSITION

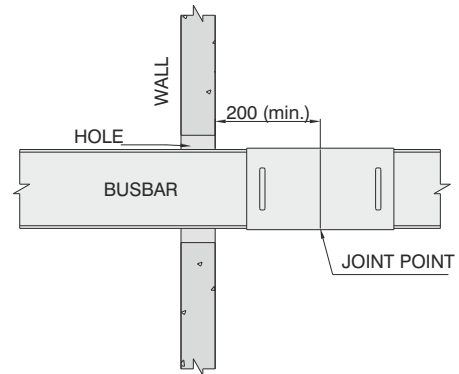

FIGURE-6 STANDARD WALL CROSSING

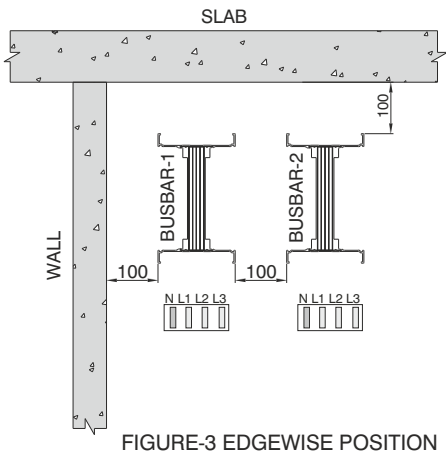

FIGURE-3 EDGEWISE POSITION

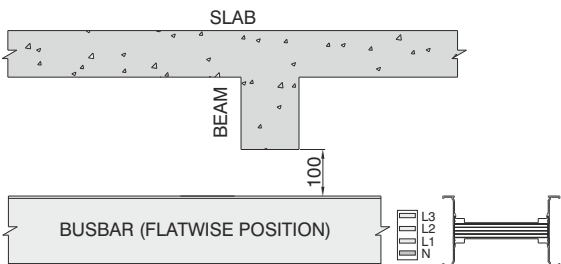
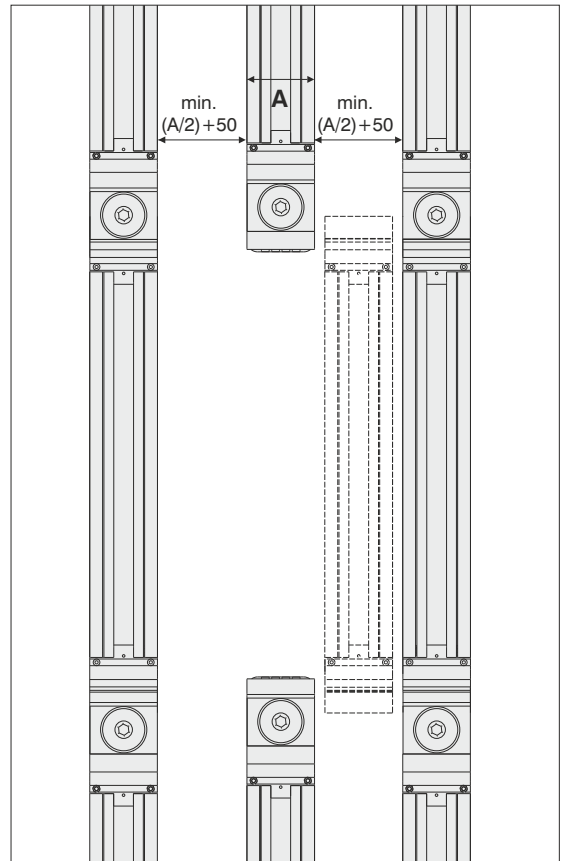

FIGURE-4 CROSSING UNDER A BEAM HORIZONTAL POSITION



MINIMUM DISTANCE BETWEEN BUSBAR RUNS IN HORIZONTAL APPLICATIONS.

The dimensions given above are minimum values.

All measures are given in mm.

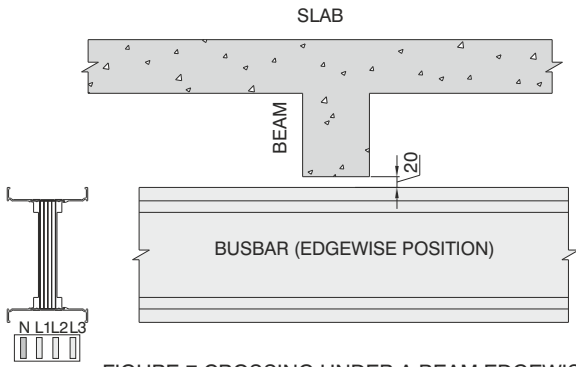

FIGURE-7 CROSSING UNDER A BEAM EDGEWISE POSITION

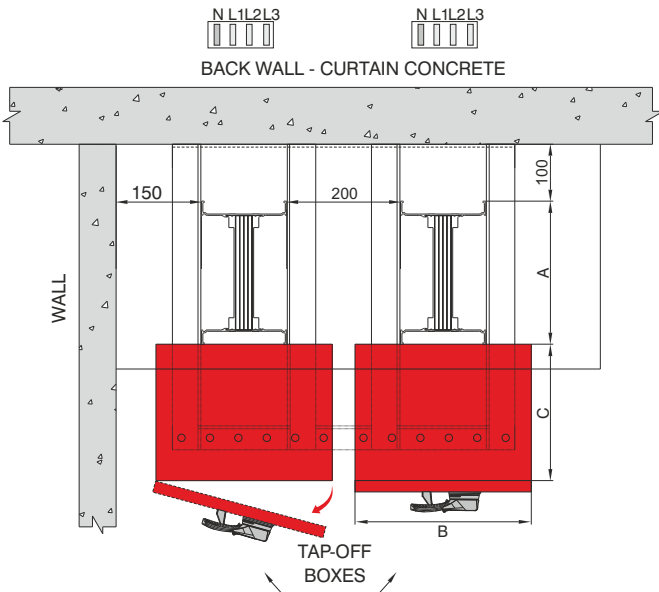

FIGURE-8 MINIMUM DIMENSIONS BETWEEN 2 TAP-OFF BOXES

Table For Outer Dimension of Busbars

KXA - Al Conductor		KXC - Cu Conductor		A (mm)
Rated Current	Busbar Code	Rated Current	Busbar Code	
400	04	550	05	77,5
500	05	650	06	82,5
630	06	800	08	91
800	08	1000	10	106
-	-	1250	12	121
1000	10	1350	14	131
-	-	1600	17	146
1250	12	-	-	161
1350	14	2000	23	176
1600	17	-	-	211
2000	20	2500	25	251
2500	27	-	-	301
-	-	2000	22	202
-	-	2500	27	232
2500	25	3300	32	312
-	-	3600	36	342
3150	32	4000	40	372
3200	33	-	-	412
4000	40	5000	50	492
5000	51	-	-	592
-	-	6300	63	732

⚠ NOTE: In order to accommodate the busbar systems in the riser shaft;

MDM= Minimum Distance from the wall

“A” dimension = All dimensions are for standard modules .

“C” dimension = Please see page 32-35 and special dimension for Tap-off box “C” dimension

“B” dimension = Max. opening distance for Tap-off box cover.

Shaft Dimension = $MDM + A + C + B + 100mm$
Shown as (Figure-8)

- The dimensions given above are minimum values.
- All measures are given in mm.

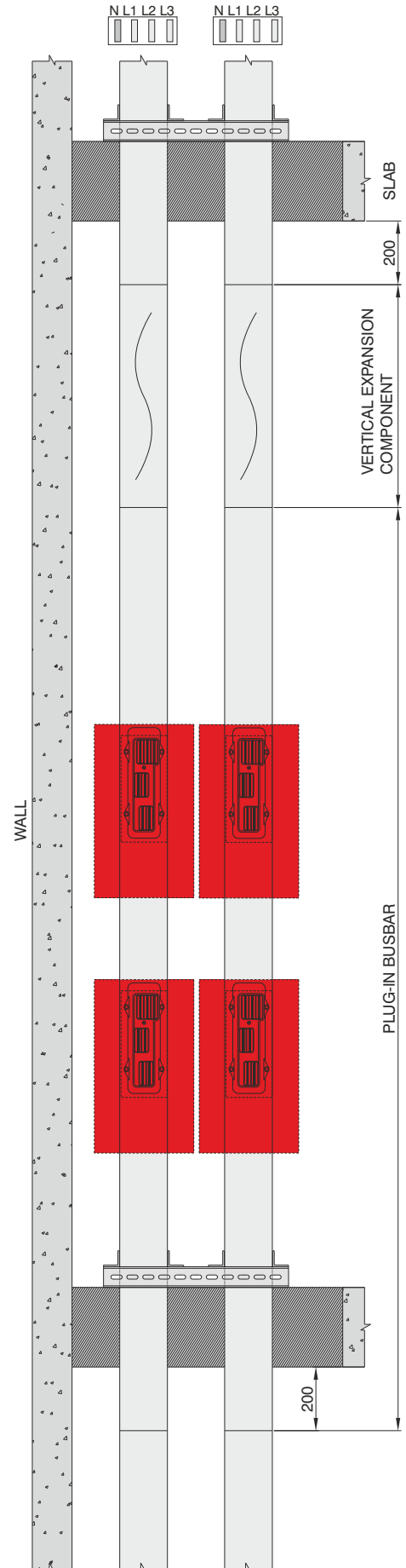
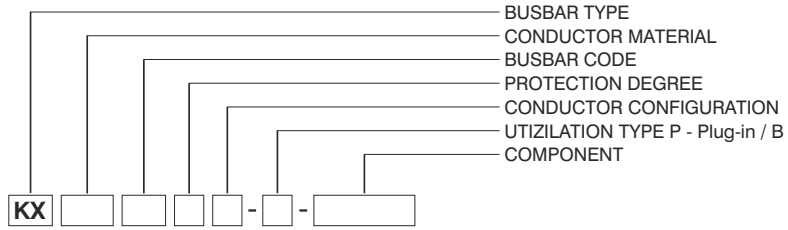

FIGURE-9 MINIMUM DIMENSIONS BETWEEN 2 RISERS

►► Feeder Boxes (B10,B11)



Cable Gland Plates

Busbar Housing Type	Cable Gland Plate	Type
		1
		2
		2
		3
		4

Feeder Box B10 - B 1 0

Sample Order:

3200 A, Aluminium, Bolt-on, 4 conductors

KXA 32504 - B - B10

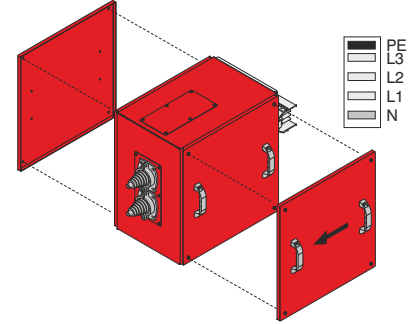

B10

Feeder Box B11 - B 1 1

Sample Order:

3600 A, Copper, Bolt-on, 4 conductors

KXC 36504 - B - B11

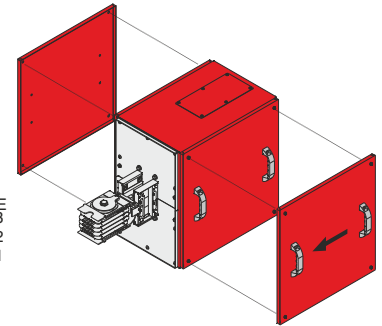

B11

Ampere Ratings

KXA - Al Conductor		KXC - Cu Conductor		A	B	C	D	Gland Type
Rated Current	Busbar Code	Rated Current	Busbar Code	(mm)	(mm)	(mm)	(mm)	
400	04	550	05	500	520	355	350	1
500	05	650	06	500	520	355	350	1
630	06	800	08	500	520	355	350	1
800	08	1000	10	500	520	355	350	1
-	-	1250	12	500	520	355	350	1
1000	10	1350	14	500	520	355	350	1
-	-	1600	17	500	520	355	350	1
1250	12	-	-	500	520	355	350	1
1350	14	2000	23	500	520	555	350	2
1600	17	-	-	500	520	555	350	2
2000	20	2500	25	500	520	555	350	2
2500	27	-	-	500	520	555	350	3
-	-	2000	22	500	520	555	350	2
-	-	2500	27	500	520	555	350	2
2500	25	3300	32	500	520	555	350	3
-	-	3600	36	500	520	555	350	3
3150	32	4000	40	700	520	770	550	3
3200	33	-	-	700	520	770	550	3
4000	40	5000	50	700	520	770	550	3
5000	51	-	-	700	520	770	550	3
-	-	6300	63	700	520	950	550	4

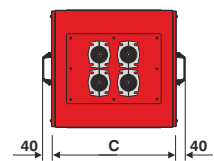
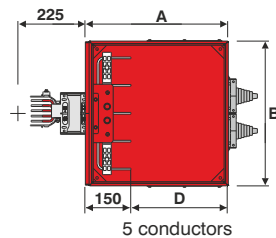
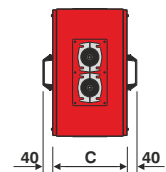
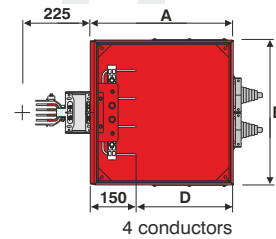

■ The dimensions given above are minimum values

■ Please call us for special applications or for applications with MCCB's.

►► Feeder Boxes (Central Feeder Boxes BO)

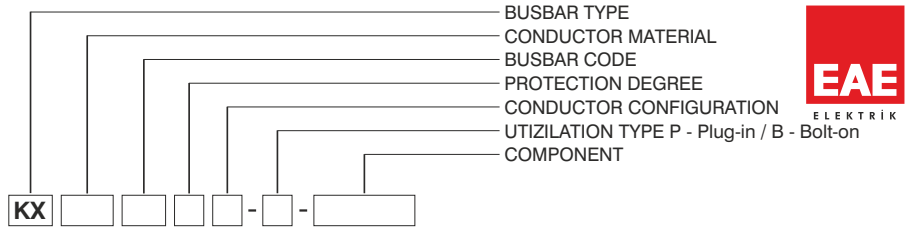

Cable Gland Plates

Busbar Housing Type	Cable Gland Plate	Type
		1
		2
		2
		3
		4

Central Feeder Box - B O

Sample Order:

2500 A, Aluminium, Bolt-on
4conductors

KXA 25504 - B - BO

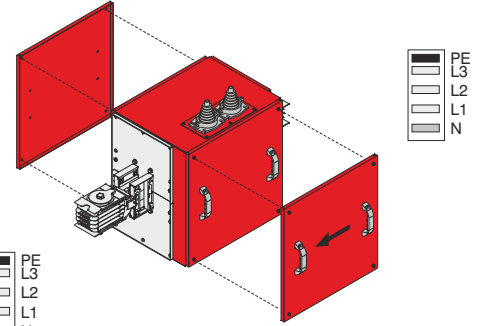

BO

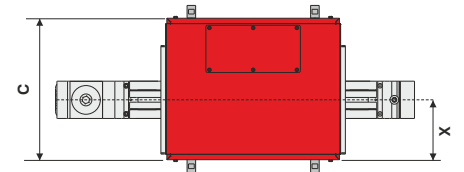

Ampere Ratings

KXA - Al Conductor		KXC - Cu Conductor		A	B	C	X	Gland Type
Rated Current	Busbar Code	Rated Current	Busbar Code	(mm)	(mm)	(mm)	(mm)	
400	04	550	05	500	520	405	175	1
500	05	650	06	500	520	405	175	1
630	06	800	08	500	520	405	175	1
800	08	1000	10	500	520	405	175	1
-	-	1250	12	500	520	405	175	1
1000	10	1350	14	500	520	405	175	1
-	-	1600	17	500	520	405	175	1
1250	12	-	-	700	520	805	175	1
1350	14	2000	23	700	520	805	277,5	2
1600	17	-	-	700	520	805	277,5	2
2000	20	2500	25	700	520	805	277,5	2
2500	27	-	-	700	520	805	277,5	2
-	-	2000	22	700	520	805	277,5	2
-	-	2500	27	700	520	805	277,5	2
-	-	3000	30	700	520	805	277,5	2
2500	25	3300	32	700	520	805	277,5	3
-	-	3600	36	700	520	805	277,5	3
3150	32	4000	40	850	520	1005	385	3
3200	33	-	-	850	520	1005	385	3
4000	40	5000	50	850	520	1005	385	3
5000	51	-	-	850	520	1005	385	3
-	-	6300	63	850	650	1005	385	4

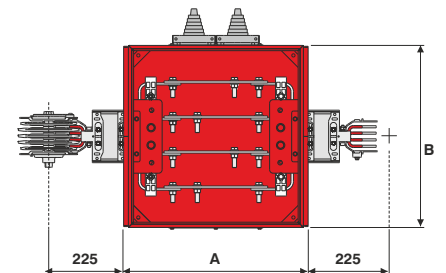

■ The dimensions given above are minimum values.

■ Please call us for special applications or for applications with MCCB's.

Supports

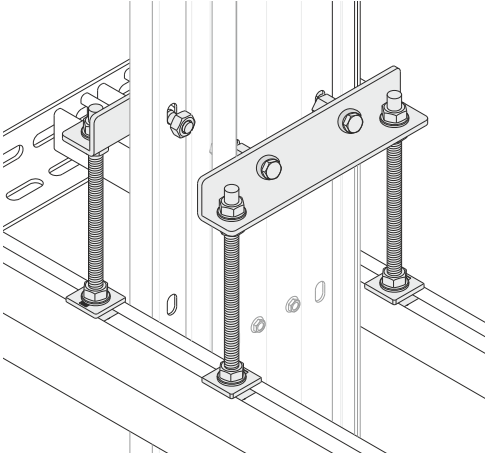

Description	Code
KX Vertical Riser Fixing Unit	3048475

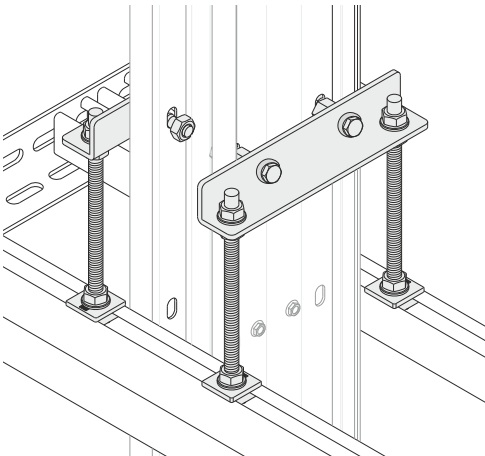
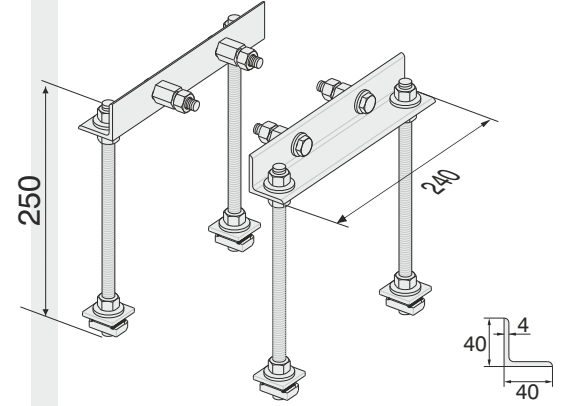

Description	Code
KX Vertical Riser Fixing Unit (Fire Barrier)	3048709

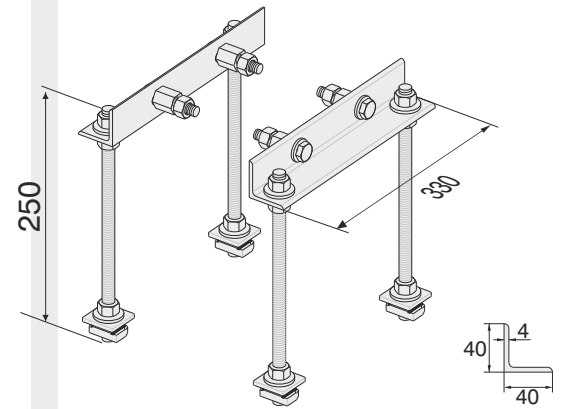

FIXING ELEMENTS



Description	Code
KX Fixing Clamp for Binrak(Unistrut) Channel	2011227

Description	Code
KX Fixing Clamp for Steel Angle Profile	2011226

■ Please call us for non-standard components.

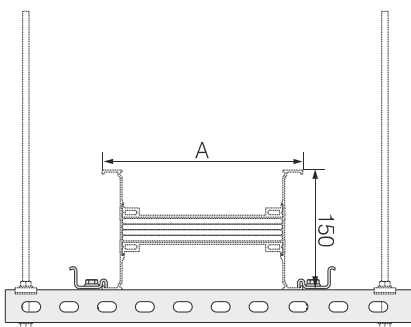
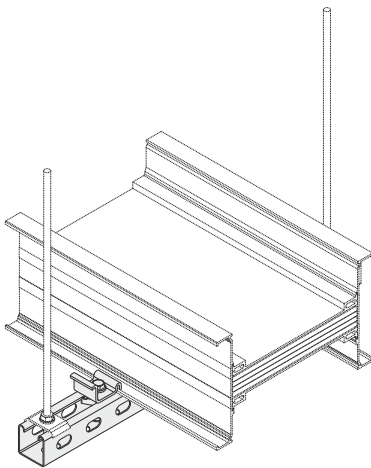
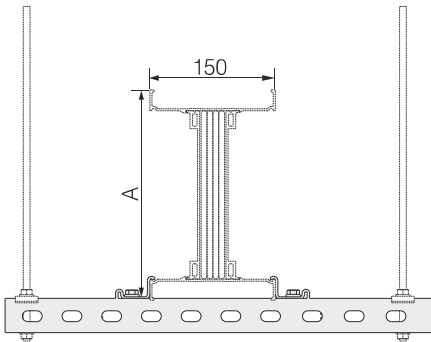
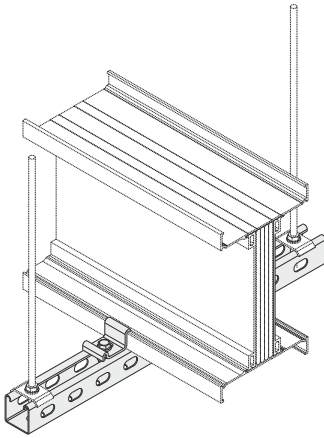

Supports
KX - BRA HANGER
SET FOR EDGEWISE
APPLICATION TO
BINRAK (UNISTRUT)
CHANNEL

KX - BRA HANGER
SET FOR FLATWISE
APPLICATION TO
BINRAK (UNISTRUT)
CHANNEL

Al Conductor		Cu Conductor		L (mm)	A (mm)	Order Code
Rated Current	Busbar Code	Rated Current	Busbar Code			
400	04	550	05	350	77,5	3025372
500	05	650	06		82,5	
630	06	800	08		91	
800	08	1000	10		106	
-	-	1250	12		121	
1000	10	1350	14		131	
-	-	1600	17		146	
1250	12	-	-		161	
1350	14	2000	23		176	
1600	17	-	-		211	
2000	20	2500	25		251	
2500	27	-	-		301	

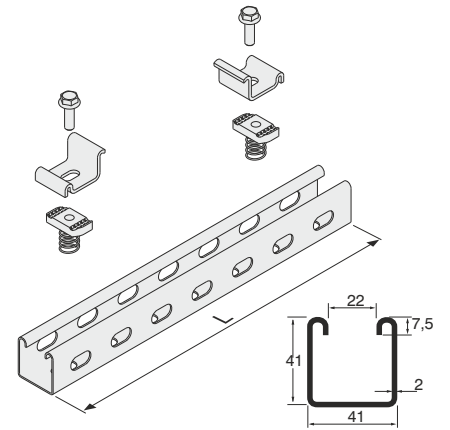

Al Conductor		Cu Conductor		L (mm)	A (mm)	Order Code
Rated Current	Busbar Code	Rated Current	Busbar Code			
400	04	550	05	300	77,5	3025372
500	05	650	06		82,5	
630	06	800	08		91	
800	08	1000	10		106	
-	-	1250	12	350	121	3025373
1000	10	1350	14		131	
-	-	1600	17	400	146	3025374
1250	12	-	-		161	
1350	14	2000	23	450	176	3025375
1600	17	-	-		211	
2000	20	2500	25	450	251	3025375
2500	27	-	-		301	

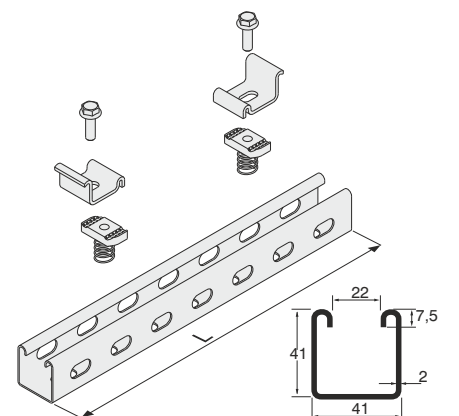

■ Please call us for non-standard components.

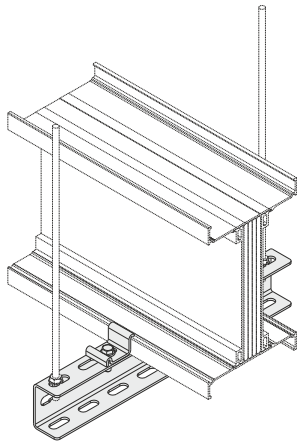

Supports KX - UT HANGER SET FOR EDGEWISE APPLICATION TO NPU CHANNEL

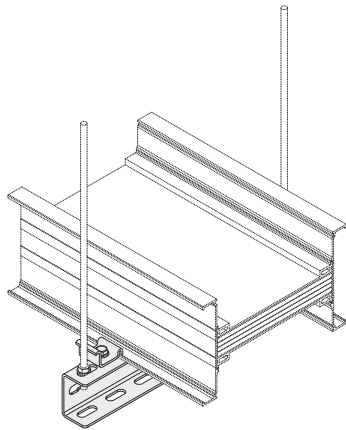
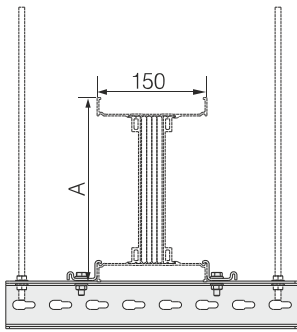
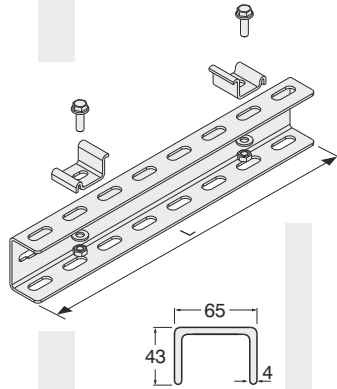

KX - UT HANGER SET FOR FLATWISE APPLICATION TO NPU CHANNEL

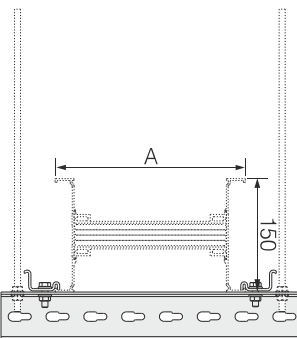
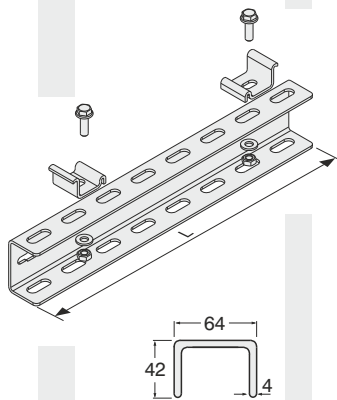

Al Conductor		Cu Conductor		L (mm)	A (mm)	Order Code
Rated Current	Busbar Code	Rated Current	Busbar Code			
400	04	550	05	350	77,5	3025348
500	05	650	06		82,5	
630	06	800	08		91	
800	08	1000	10		106	
-	-	1250	12		121	
1000	10	1350	14		131	
-	-	1600	17		146	
1250	12	-	-		161	
1350	14	2000	23		176	
1600	17	-	-		211	
2000	20	2500	25		251	
2500	27	-	-		301	
-	-	2000	22		202	
-	-	2500	27		232	
2500	25	3300	32		312	
-	-	3600	36		342	
3150	32	4000	40		372	
3200	33	-	-		412	
4000	40	5000	50		492	
5000	51	-	-		592	
-	-	6300	63	732		

Al Conductor		Cu Conductor		L (mm)	A (mm)	Order Code
Rated Current	Busbar Code	Rated Current	Busbar Code			
400	04	550	05	300	77,5	3025347
500	05	650	06		82,5	
630	06	800	08		91	
800	08	1000	10		106	
-	-	1250	12	350	121	3025348
1000	10	1350	14		131	
-	-	1600	17	400	146	3025349
1250	12	-	-		161	
1350	14	2000	23	450	176	3025350
1600	17	-	-		211	
2000	20	2500	25	400	251	3025349
2500	27	-	-		301	
-	-	2000	22	450	202	3025349
-	-	2500	27		232	
2500	25	3300	32	500	312	3025351
-	-	3600	36		342	
3150	32	4000	40	550	372	3025352
3200	33	-	-		412	
4000	40	5000	50	600	492	3025353
5000	51	-	-		700	
-	-	-	-	800	592	3134130
-	-	6300	63		732	

■ Please call us for non-standard components.

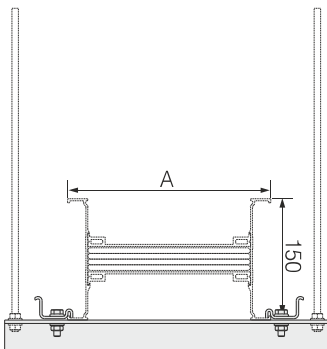
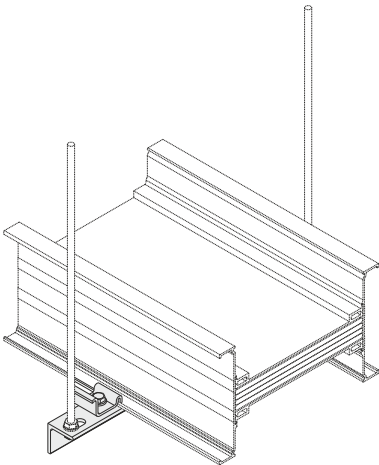
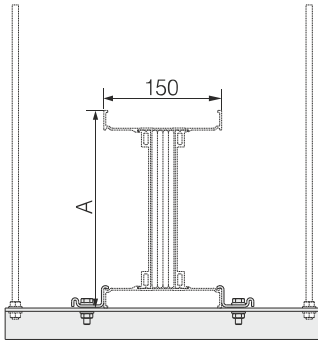
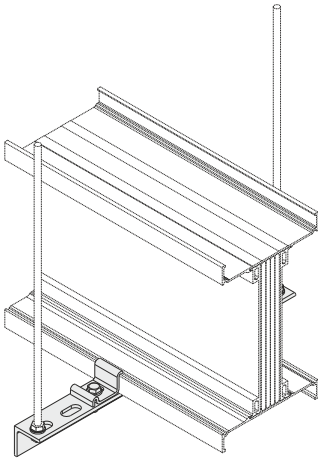

Supports
KX HANGER
SET FOR EDGEWISE
APPLICATION
TO STEEL ANGLE
PROFILE

KX HANGER
SET FOR FLATWISE
APPLICATION
TO STEEL ANGLE
PROFILE

Al Conductor		Cu Conductor		L (mm)	A (mm)	Order Code
Rated Current	Busbar Code	Rated Current	Busbar Code			
400	04	550	05	350	77,5	3025344
500	05	650	06		82,5	
630	06	800	08		91	
800	08	1000	10		106	
-	-	1250	12		121	
1000	10	1350	14		131	
-	-	1600	17		146	
1250	12	-	-		161	
1350	14	2000	23		176	
1600	17	-	-		211	
2000	20	2500	25		251	
2500	27	-	-		301	

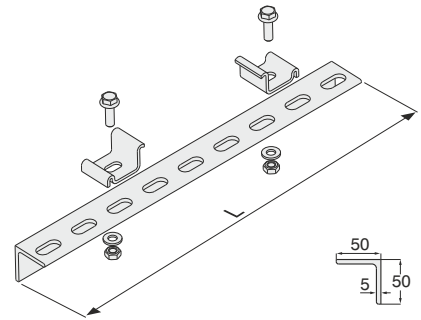

Al Conductor		Cu Conductor		L (mm)	A (mm)	Order Code
Rated Current	Busbar Code	Rated Current	Busbar Code			
400	04	550	05	300	77,5	3025343
500	05	650	06		82,5	
630	06	800	08		91	
800	08	1000	10		106	
-	-	1250	12	350	121	3025344
1000	10	1350	14		131	
-	-	1600	17	400	146	3025345
1250	12	-	-		161	
1350	14	2000	23	450	176	3025346
1600	17	-	-		211	
2000	20	2500	25	450	251	3025346
2500	27	-	-		301	

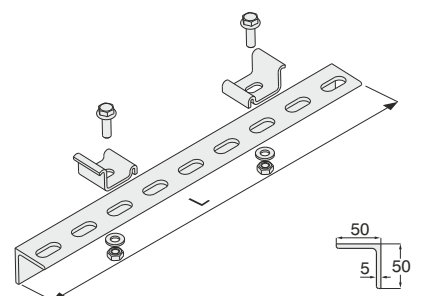

■ Please call us for non-standard components.

Supports

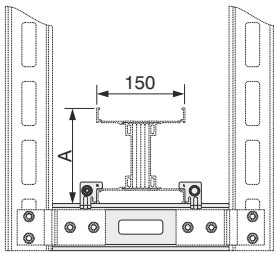
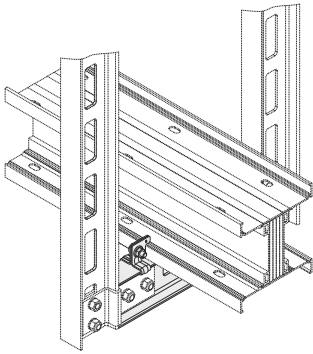
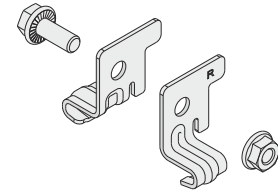

**KX - IDY TWO-WAY
FOR EDGEWISE
APPLICATION
TO NPI CHANNEL**

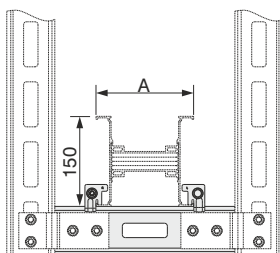
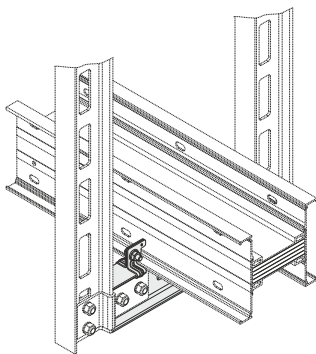
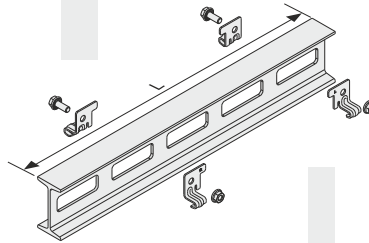

**KX - IDY TWO-WAY
FOR FLATWISE
APPLICATION
TO NPI CHANNEL**

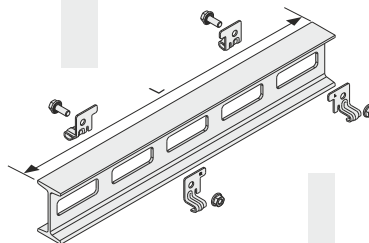

Description	Code
KX IDY Support Set	2054590

Al Conductor		Cu Conductor		L (mm)	A (mm)	Order Code
Rated Current	Busbar Code	Rated Current	Busbar Code			
400	04	550	05	300	77,5	3113547
500	05	650	06		82,5	
630	06	800	08		91	
800	08	1000	10		106	
-	-	1250	12		121	
1000	10	1350	14		131	
-	-	1600	17		146	
1250	12	-	-		161	
1350	14	2000	23		176	
1600	17	-	-		211	
2000	20	2500	25		251	
2500	27	-	-		301	
-	-	2000	22		202	
-	-	2500	27		232	
2500	25	3300	32		312	
-	-	3600	36		342	
3150	32	4000	40	372		
3200	33	-	-	412		
4000	40	5000	50	492		
5000	51	-	-	592		
-	-	6300	63	732		

Al Conductor		Cu Conductor		L (mm)	A (mm)	Order Code
Rated Current	Busbar Code	Rated Current	Busbar Code			
400	04	550	05	300	77,5	3113547
500	05	650	06		82,5	
630	06	800	08		91	
800	08	1000	10		106	
-	-	1250	12		121	
1000	10	1350	14		131	
-	-	1600	17		146	
1250	12	-	-		161	
1350	14	2000	23		176	
1600	17	-	-		211	
2000	20	2500	25		251	
2500	27	-	-		301	
-	-	2000	22		202	
-	-	2500	27		232	
2500	25	3300	32		312	
-	-	3600	36		342	
3150	32	4000	40	372		
3200	33	-	-	412		
4000	40	5000	50	492		
5000	51	-	-	592		
-	-	6300	63	732		

■ Please call us for non-standard components.

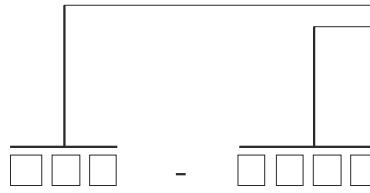

Supports

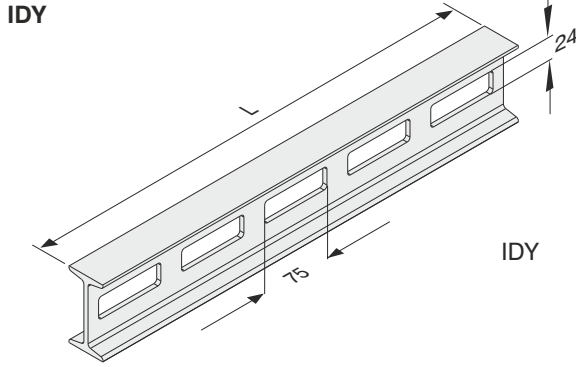

IDY

IDY

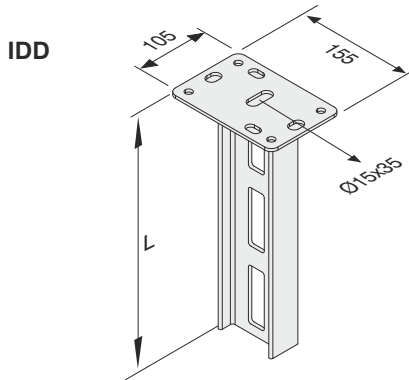

IDD

IDD

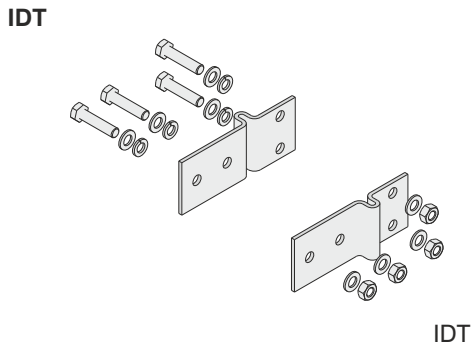

IDT

IDT

Description	L (mm)	Code
IDY 300	300	3008242
IDY 400	400	3008290
IDY 500	500	3008289
IDY 600	600	3008288
IDY 700	700	3008287
IDY 800	800	3008286
IDY 900	900	3008285
IDY 1000	1000	3008284
IDY 1100	1100	3008283
IDY 1200	1200	3008282
IDY 1300	1300	3008236
IDY 1400	1400	3008281
IDY 1500	1500	3008280
IDY 1600	1600	3008241
IDY 1700	1700	3008240
IDY 1800	1800	3008239
IDY 1900	1900	3008238
IDY 2000	2000	3008237

IDD 300	300	3008314
IDD 400	400	3008313
IDD 500	500	3008312
IDD 600	600	3008311
IDD 700	700	3008310
IDD 800	800	3008309
IDD 900	900	3008308
IDD 1000	1000	3008307
IDD 1100	1100	3008306
IDD 1200	1200	3008305
IDD 1300	1300	3008304
IDD 1400	1400	3008303
IDD 1500	1500	3008302
IDD 1600	1600	3008301
IDD 1700	1700	3008300
IDD 1800	1800	3008299
IDD 1900	1900	3008298
IDD 2000	2000	3008297

IDT Support Fitting	-	3008279
---------------------	---	---------

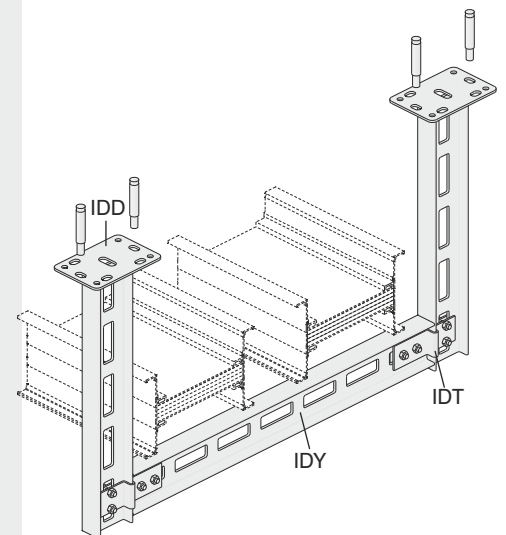

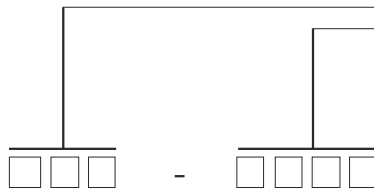

Supports

UPY

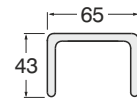
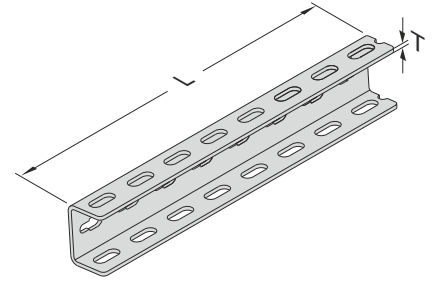
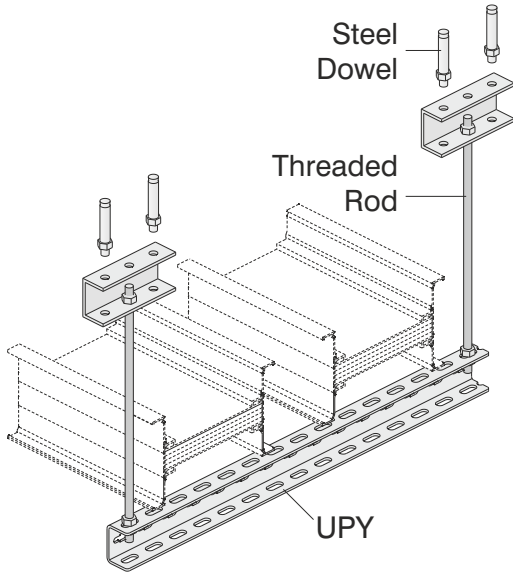

Description	T (mm)	L (mm)	Code
UPY 300	4	300	3004487
UPY 400	4	400	3004489
UPY 500	4	500	3004491
UPY 600	4	600	3004493
UPY 700	4	700	3004495
UPY 800	4	800	3004496
UPY 900	4	900	3004497
UPY 1000	4	1000	3004498
UPY 1100	4	1100	3004499
UPY 1200	4	1200	3004500
UPY 1500	4	1500	3004503

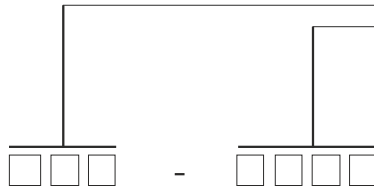

Supports

UDY

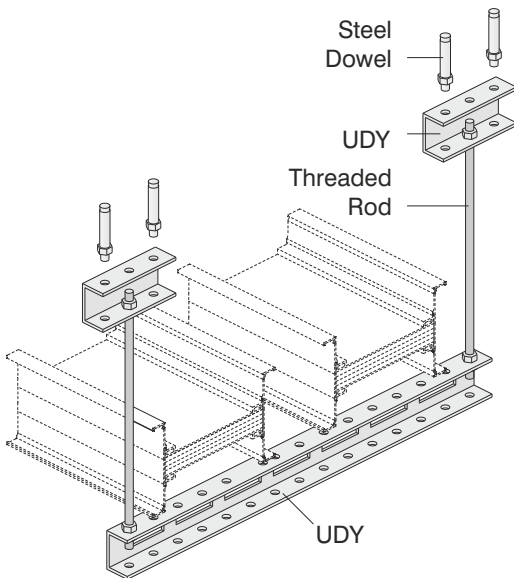
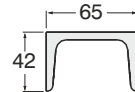
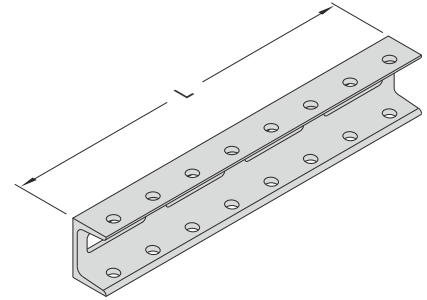
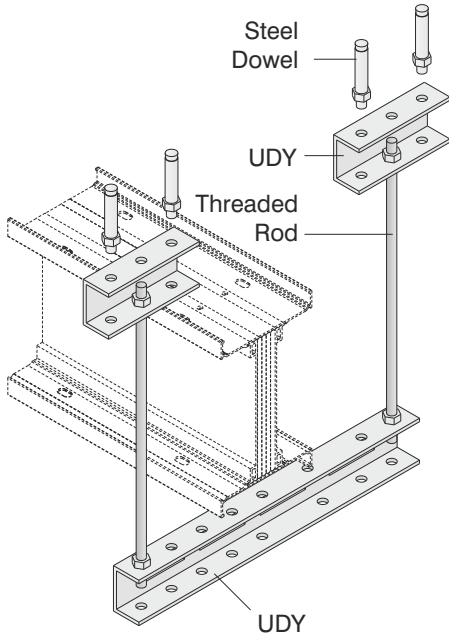

Description	L (mm)	Code
UDY 300	300	3008023
UDY 400	400	3008024
UDY 500	500	3008025
UDY 600	600	3008026
UDY 700	700	3008027
UDY 800	800	3008028
UDY 900	900	3008029
UDY 1000	1000	3008030
UDY 1100	1100	3008031
UDY 1200	1200	3008032
UDY 1300	1300	3008033
UDY 1400	1400	3008034
UDY 1500	1500	3008035
UDY 1600	1600	3008036
UDY 1700	1700	3008037
UDY 1800	1800	3008038
UDY 1900	1900	3008039
UDY 2000	2000	3008040

■ Please call us for non-standard components.

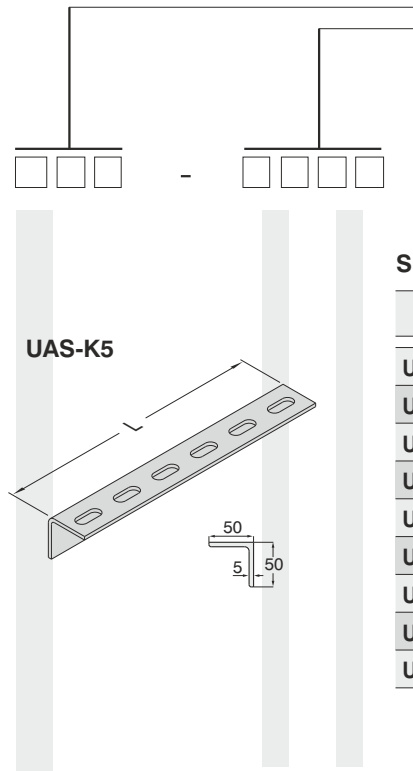
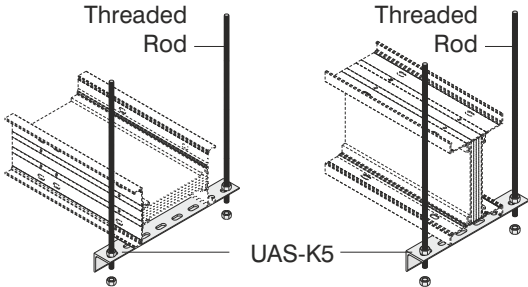

Supports

Description	L (mm)	Code
UAS-K5 SUPPORT (1)	200	3005324
UAS-K5 SUPPORT (2)	250	3005323
UAS-K5 SUPPORT (3)	300	3005322
UAS-K5 SUPPORT (4)	350	3005321
UAS-K5 SUPPORT (5)	400	3005320
UAS-K5 SUPPORT (6)	500	3005319
UAS-K5 SUPPORT (7)	600	3005318
UAS-K5 SUPPORT (8)	700	3005317
UAS-K5 SUPPORT (9)	1100	3005316

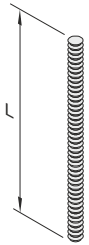

Threaded Rod



Extension Unit



Steel Dowel

Diameter of the hole to be drilled
M10.....Ø14
M12.....Ø16



Steel Nut



Washer

Connection Units

Description	L (mm)	Code
BRA 12-05 Threaded Rod (M10)	500	5000037
BRA 12-10 Threaded Rod (M10)	1000	5000032
BRA 14-05 Threaded Rod (M12)	500	5000026
BRA 14-10 Threaded Rod (M12)	1000	5000034
BRA 13 Extension Unit (M10)	-	1004312
BRA 13 Extension Unit (M12)	-	1004282
BRA 9 Steel Dowel (M10)	-	5000023
BRA 9 Steel Dowel (M12)	-	5000022
M10 Steel Nut	-	1000522
M12 Steel Nut	-	1000964
M10 Washer	-	1000504
M12 Washer	-	1000505

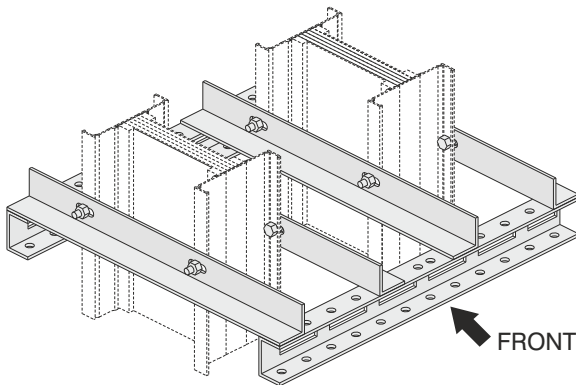

Vertical Riser Application
Sample Order Hanging
(Special to project)

■ Please call us for non-standard components.

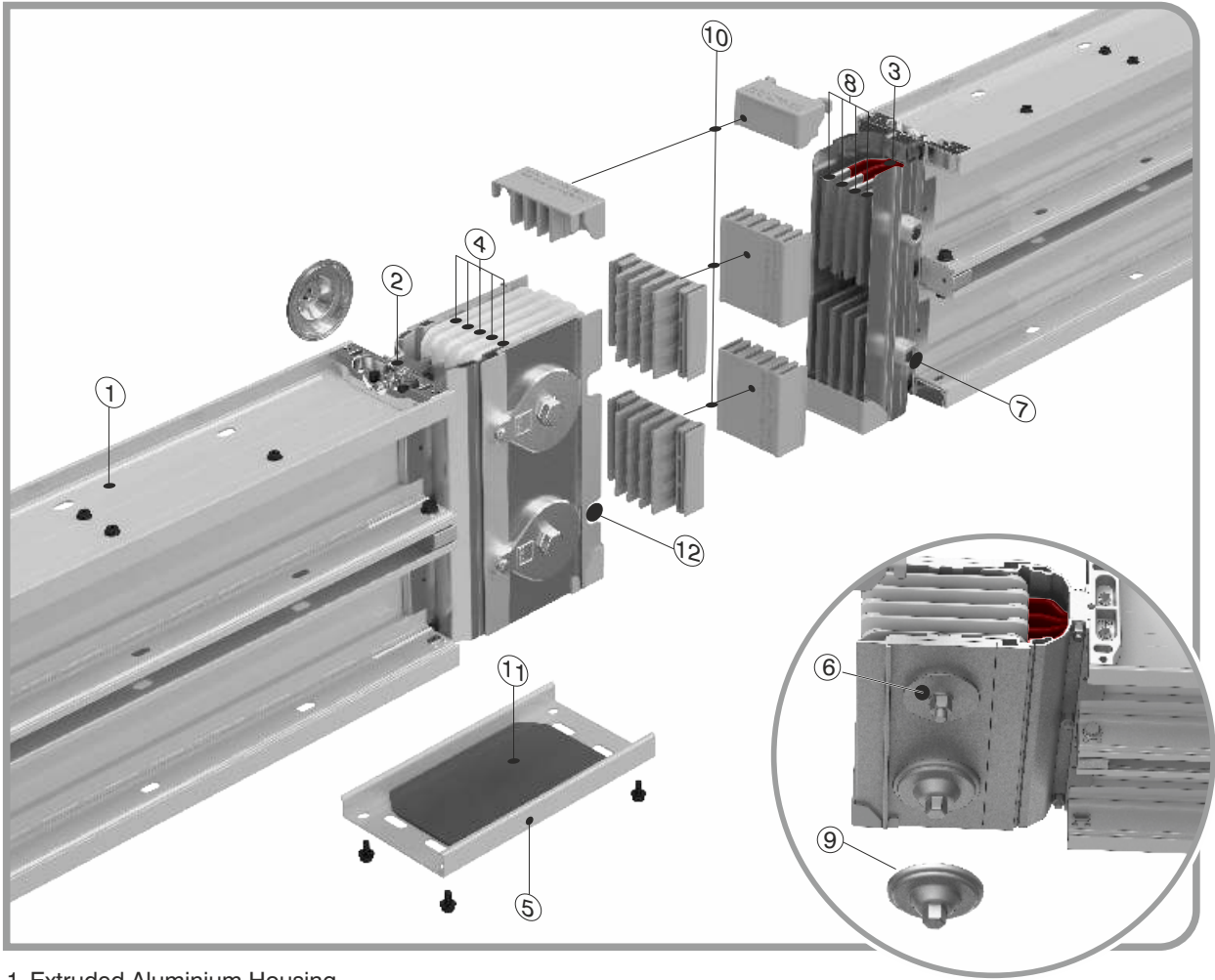

- 1- Extruded Aluminium Housing
- 2- PE Fixing Piece
- 3- Insulation Layers (Epoxy+B class polyester film)
- 4- Joint Insulators
- 5- Joint Cover
- 6- Belleville
- 7- Alignment Pin (removable)
- 8- Conductors
- 9- IP55 Nut Locking Piece
- 10- Protection Plastic
- 11- IP55 Joint Cover Gasket
- 12- Alignment Pin Slot

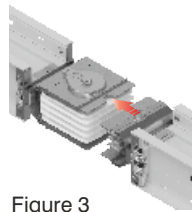

Figure 3

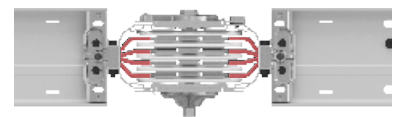

Figure 4

Joint assembly

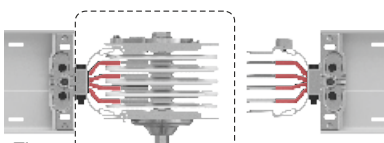

Figure 1

Block Joint

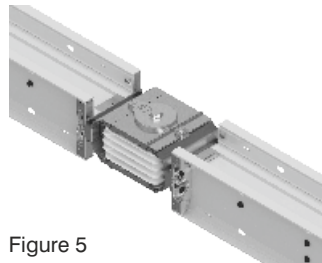

Figure 5

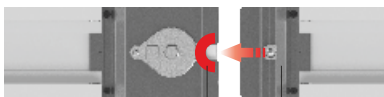

Figure 2

Alignment Slot

Alignment Pin (removable)

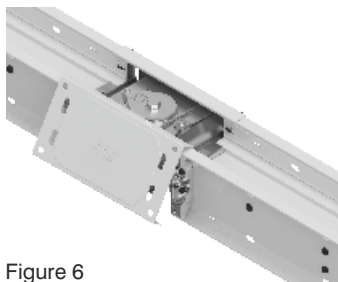
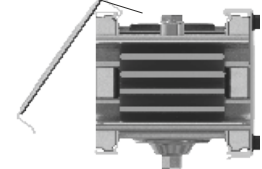

Figure 6

The joint cover is closed by leverage.



Please check related installation manual for details.

▶▶ Measuring a Special Length

After installation of standard busbar 3m lengths, you will be in need of special lengths which are smaller than 3m. The minimum length for these special elements can be 35 cm. Please measure the lengths of these modules as shown below.

Length A is measured between housing of 2 busbars in cm. A. The special length is calculated by deducting 25 cm from this measured length.

$X = A - 25$ (cm) X = Length of Special Busbar (The busbar module will be manufactured as per X value.)

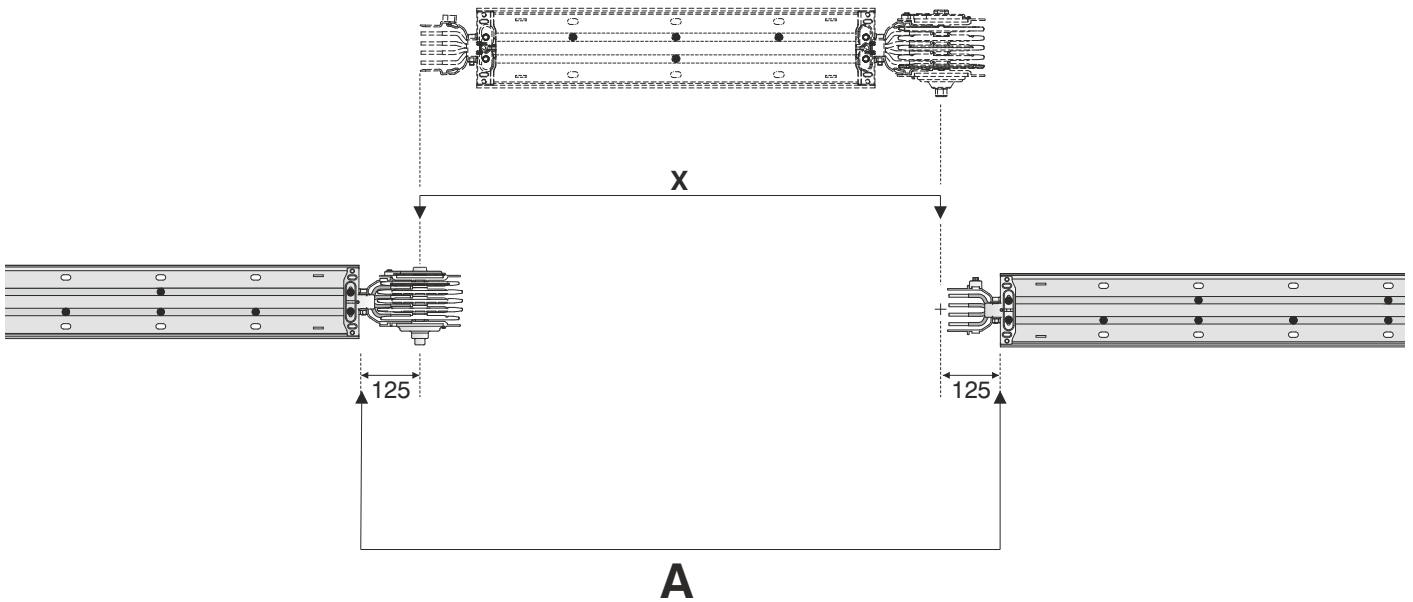

▶▶ Inserting "Make up Section"

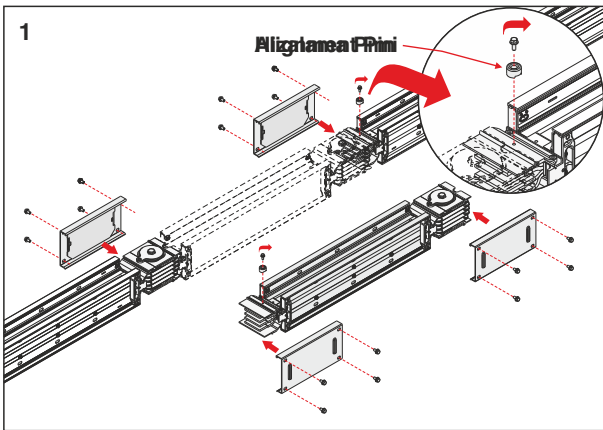

1- Remove Alignment Pin on the busbar, without block joint.

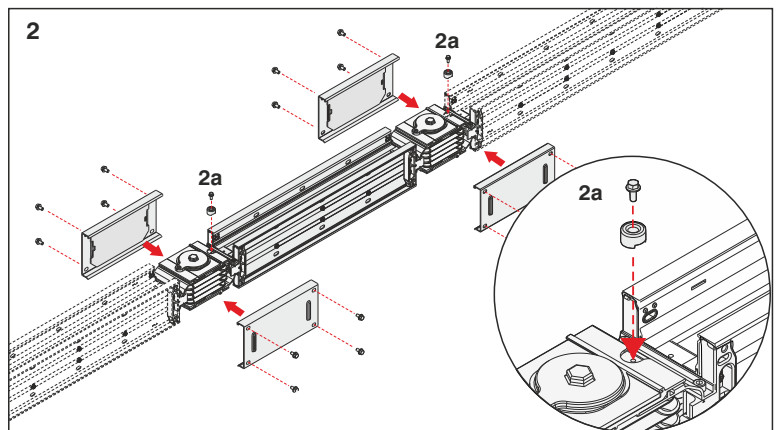

2- Insert the piece aligning conductors correctly. Fix back the Alignment pin.

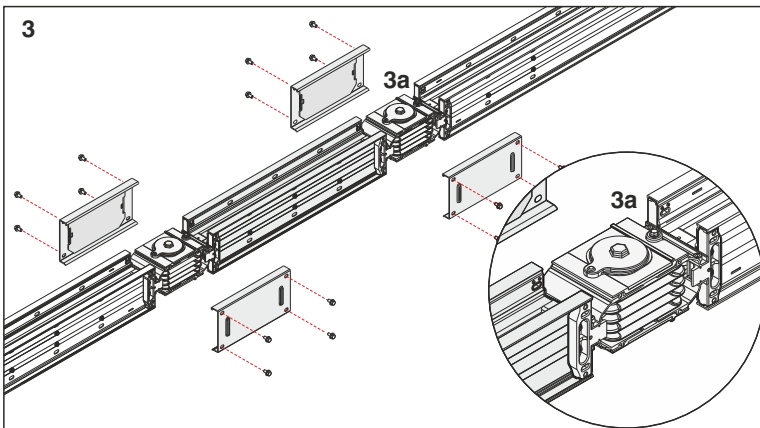

3- Make sure busbar piece is aligned according to alignment pin.

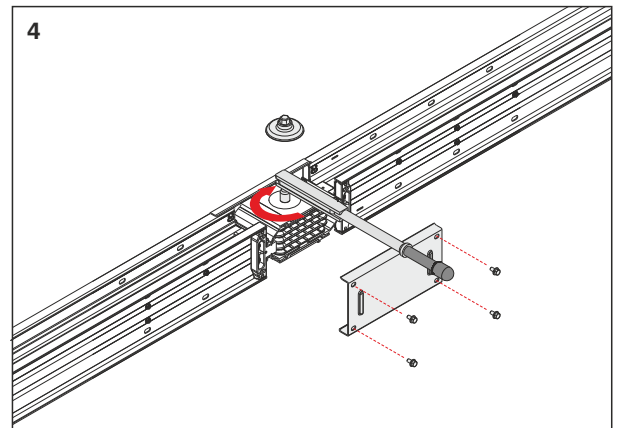

4- Fix one of the joint cover to stabilize joint. Apply 83Nm to the main bolt.

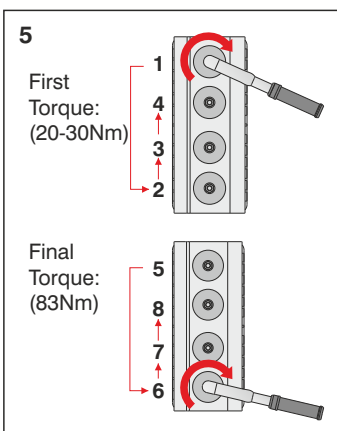

5- If there are more than one bolt for the same phase, bolts shall be tightened by hand approximately 20-30Nm as per above sequence, then 83Nm shall be applied at final torque with the same sequence.

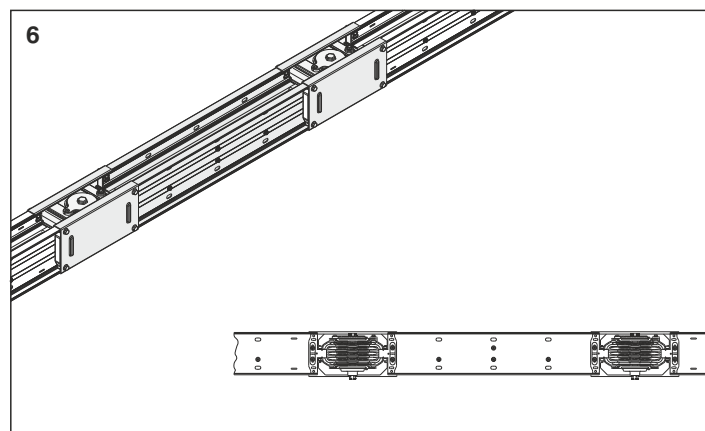

6- Fix the remaining joint cover. Joint installation is completed.

Note: If the final joint cover does not close correctly, it indicates the busbar is not completely aligned. Release the bolts and reapply the sequence from figure 4 to complete the joint.

Please check related installation manual for details.

CE DECLARATION OF CONFORMITY

Product Group E-Line KX Busbar Energy Distribution System

Manufacturer EAE Elektrik Asansor End. Insaat San. ve Tic. A.S.
Akcaburgaz Mahallesi, 3114. Sokak,
No:10 34522 Esenyurt-Istanbul

The objects of the declaration described below is in conformity with the relevant Union harmonisation legislation. This declaration of conformity is issued under the sole responsibility of the manufacturer.

Standard :**EN 61439-6**

Low-voltage switchgear and controlgear assemblies - Part 6: Busbar trunking systems

IEC 61439-6

Low-voltage switchgear and controlgear assemblies - Part 6: Busbar trunking systems (busways)

CE - Directive

2014/35/EU "The Low Voltage Directive"

2014/30/EU "Electromagnetic Compatibility (EMC) Directive"

2011/65/EU "Restriction of the use of certain hazardous substances (RoHS)"

Technical Document Preparation Official:

EAE Elektrik Asansor End. Insaat San. ve Tic. A.S.
Akcaburgaz Mahallesi, 3114. Sokak, No:10 34522 Esenyurt-Istanbul

Emre GÜRLEYEN

Date

20.04.2016

Document Authorized Signatory

Elif Gamze KAYA OK
Deputy General Manager



CERTIFICATE

EAE Elektrik As
Insaat San. ve T
Akçaburgaz Ma
34510 Esenyur
Turkey

For the product: Low-voltage busbar trunking system

EAE
KXA05

Ui 1000 V, Uimp
lcw 25 kA - 1 s
for more details

z, IP55

EAE Elektrik As
Insaat San. ve T
Akçaburgaz Ma
34510 Esenyur
Turkey

Subject: Design verification

Requirements: IEC 61439-6: 2012
Clauses: 10.2, 10.3, 10.4, 10.5, 10.6, 10.7, 10.8, 10.9, 10.10, 10.11, 10.12, 10.13, 10.14, 10.15, 10.16, 10.17, 10.18, 10.19, 10.20, 10.21, 10.22, 10.23, 10.24, 10.25, 10.26, 10.27, 10.28, 10.29, 10.30, 10.31, 10.32, 10.33, 10.34, 10.35, 10.36, 10.37, 10.38, 10.39, 10.40, 10.41, 10.42, 10.43, 10.44, 10.45, 10.46, 10.47, 10.48, 10.49, 10.50, 10.51, 10.52, 10.53, 10.54, 10.55, 10.56, 10.57, 10.58, 10.59, 10.60, 10.61, 10.62, 10.63, 10.64, 10.65, 10.66, 10.67, 10.68, 10.69, 10.70, 10.71, 10.72, 10.73, 10.74, 10.75, 10.76, 10.77, 10.78, 10.79, 10.80, 10.81, 10.82, 10.83, 10.84, 10.85, 10.86, 10.87, 10.88, 10.89, 10.90, 10.91, 10.92, 10.93, 10.94, 10.95, 10.96, 10.97, 10.98, 10.99, 10.100, 10.101, 10.102, 10.103, 10.104, 10.105, 10.106, 10.107, 10.108, 10.109, 10.110, 10.111, 10.112, 10.113, 10.114, 10.115, 10.116, 10.117, 10.118, 10.119, 10.120, 10.121, 10.122, 10.123, 10.124, 10.125, 10.126, 10.127, 10.128, 10.129, 10.130, 10.131, 10.132, 10.133, 10.134, 10.135, 10.136, 10.137, 10.138, 10.139, 10.140, 10.141, 10.142, 10.143, 10.144, 10.145, 10.146, 10.147, 10.148, 10.149, 10.150, 10.151, 10.152, 10.153, 10.154, 10.155, 10.156, 10.157, 10.158, 10.159, 10.160, 10.161, 10.162, 10.163, 10.164, 10.165, 10.166, 10.167, 10.168, 10.169, 10.170, 10.171, 10.172, 10.173, 10.174, 10.175, 10.176, 10.177, 10.178, 10.179, 10.180, 10.181, 10.182, 10.183, 10.184, 10.185, 10.186, 10.187, 10.188, 10.189, 10.190, 10.191, 10.192, 10.193, 10.194, 10.195, 10.196, 10.197, 10.198, 10.199, 10.200, 10.201, 10.202, 10.203, 10.204, 10.205, 10.206, 10.207, 10.208, 10.209, 10.210, 10.211, 10.212, 10.213, 10.214, 10.215, 10.216, 10.217, 10.218, 10.219, 10.220, 10.221, 10.222, 10.223, 10.224, 10.225, 10.226, 10.227, 10.228, 10.229, 10.230, 10.231, 10.232, 10.233, 10.234, 10.235, 10.236, 10.237, 10.238, 10.239, 10.240, 10.241, 10.242, 10.243, 10.244, 10.245, 10.246, 10.247, 10.248, 10.249, 10.250, 10.251, 10.252, 10.253, 10.254, 10.255, 10.256, 10.257, 10.258, 10.259, 10.260, 10.261, 10.262, 10.263, 10.264, 10.265, 10.266, 10.267, 10.268, 10.269, 10.270, 10.271, 10.272, 10.273, 10.274, 10.275, 10.276, 10.277, 10.278, 10.279, 10.280, 10.281, 10.282, 10.283, 10.284, 10.285, 10.286, 10.287, 10.288, 10.289, 10.290, 10.291, 10.292, 10.293, 10.294, 10.295, 10.296, 10.297, 10.298, 10.299, 10.300, 10.301, 10.302, 10.303, 10.304, 10.305, 10.306, 10.307, 10.308, 10.309, 10.310, 10.311, 10.312, 10.313, 10.314, 10.315, 10.316, 10.317, 10.318, 10.319, 10.320, 10.321, 10.322, 10.323, 10.324, 10.325, 10.326, 10.327, 10.328, 10.329, 10.330, 10.331, 10.332, 10.333, 10.334, 10.335, 10.336, 10.337, 10.338, 10.339, 10.340, 10.341, 10.342, 10.343, 10.344, 10.345, 10.346, 10.347, 10.348, 10.349, 10.350, 10.351, 10.352, 10.353, 10.354, 10.355, 10.356, 10.357, 10.358, 10.359, 10.360, 10.361, 10.362, 10.363, 10.364, 10.365, 10.366, 10.367, 10.368, 10.369, 10.370, 10.371, 10.372, 10.373, 10.374, 10.375, 10.376, 10.377, 10.378, 10.379, 10.380, 10.381, 10.382, 10.383, 10.384, 10.385, 10.386, 10.387, 10.388, 10.389, 10.390, 10.391, 10.392, 10.393, 10.394, 10.395, 10.396, 10.397, 10.398, 10.399, 10.400, 10.401, 10.402, 10.403, 10.404, 10.405, 10.406, 10.407, 10.408, 10.409, 10.410, 10.411, 10.412, 10.413, 10.414, 10.415, 10.416, 10.417, 10.418, 10.419, 10.420, 10.421, 10.422, 10.423, 10.424, 10.425, 10.426, 10.427, 10.428, 10.429, 10.430, 10.431, 10.432, 10.433, 10.434, 10.435, 10.436, 10.437, 10.438, 10.439, 10.440, 10.441, 10.442, 10.443, 10.444, 10.445, 10.446, 10.447, 10.448, 10.449, 10.450, 10.451, 10.452, 10.453, 10.454, 10.455, 10.456, 10.457, 10.458, 10.459, 10.460, 10.461, 10.462, 10.463, 10.464, 10.465, 10.466, 10.467, 10.468, 10.469, 10.470, 10.471, 10.472, 10.473, 10.474, 10.475, 10.476, 10.477, 10.478, 10.479, 10.480, 10.481, 10.482, 10.483, 10.484, 10.485, 10.486, 10.487, 10.488, 10.489, 10.490, 10.491, 10.492, 10.493, 10.494, 10.495, 10.496, 10.497, 10.498, 10.499, 10.500, 10.501, 10.502, 10.503, 10.504, 10.505, 10.506, 10.507, 10.508, 10.509, 10.510, 10.511, 10.512, 10.513, 10.514, 10.515, 10.516, 10.517, 10.518, 10.519, 10.520, 10.521, 10.522, 10.523, 10.524, 10.525, 10.526, 10.527, 10.528, 10.529, 10.530, 10.531, 10.532, 10.533, 10.534, 10.535, 10.536, 10.537, 10.538, 10.539, 10.540, 10.541, 10.542, 10.543, 10.544, 10.545, 10.546, 10.547, 10.548, 10.549, 10.550, 10.551, 10.552, 10.553, 10.554, 10.555, 10.556, 10.557, 10.558, 10.559, 10.560, 10.561, 10.562, 10.563, 10.564, 10.565, 10.566, 10.567, 10.568, 10.569, 10.570, 10.571, 10.572, 10.573, 10.574, 10.575, 10.576, 10.577, 10.578, 10.579, 10.580, 10.581, 10.582, 10.583, 10.584, 10.585, 10.586, 10.587, 10.588, 10.589, 10.590, 10.591, 10.592, 10.593, 10.594, 10.595, 10.596, 10.597, 10.598, 10.599, 10.600, 10.601, 10.602, 10.603, 10.604, 10.605, 10.606, 10.607, 10.608, 10.609, 10.610, 10.611, 10.612, 10.613, 10.614, 10.615, 10.616, 10.617, 10.618, 10.619, 10.620, 10.621, 10.622, 10.623, 10.624, 10.625, 10.626, 10.627, 10.628, 10.629, 10.630, 10.631, 10.632, 10.633, 10.634, 10.635, 10.636, 10.637, 10.638, 10.639, 10.640, 10.641, 10.642, 10.643, 10.644, 10.645, 10.646, 10.647, 10.648, 10.649, 10.650, 10.651, 10.652, 10.653, 10.654, 10.655, 10.656, 10.657, 10.658, 10.659, 10.660, 10.661, 10.662, 10.663, 10.664, 10.665, 10.666, 10.667, 10.668, 10.669, 10.670, 10.671, 10.672, 10.673, 10.674, 10.675, 10.676, 10.677, 10.678, 10.679, 10.680, 10.681, 10.682, 10.683, 10.684, 10.685, 10.686, 10.687, 10.688, 10.689, 10.690, 10.691, 10.692, 10.693, 10.694, 10.695, 10.696, 10.697, 10.698, 10.699, 10.700, 10.701, 10.702, 10.703, 10.704, 10.705, 10.706, 10.707, 10.708, 10.709, 10.710, 10.711, 10.712, 10.713, 10.714, 10.715, 10.716, 10.717, 10.718, 10.719, 10.720, 10.721, 10.722, 10.723, 10.724, 10.725, 10.726, 10.727, 10.728, 10.729, 10.730, 10.731, 10.732, 10.733, 10.734, 10.735, 10.736, 10.737, 10.738, 10.739, 10.740, 10.741, 10.742, 10.743, 10.744, 10.745, 10.746, 10.747, 10.748, 10.749, 10.750, 10.751, 10.752, 10.753, 10.754, 10.755, 10.756, 10.757, 10.758, 10.759, 10.760, 10.761, 10.762, 10.763, 10.764, 10.765, 10.766, 10.767, 10.768, 10.769, 10.770, 10.771, 10.772, 10.773, 10.774, 10.775, 10.776, 10.777, 10.778, 10.779, 10.780, 10.781, 10.782, 10.783, 10.784, 10.785, 10.786, 10.787, 10.788, 10.789, 10.790, 10.791, 10.792, 10.793, 10.794, 10.795, 10.796, 10.797, 10.798, 10.799, 10.800, 10.801, 10.802, 10.803, 10.804, 10.805, 10.806, 10.807, 10.808, 10.809, 10.810, 10.811, 10.812, 10.813, 10.814, 10.815, 10.816, 10.817, 10.818, 10.819, 10.820, 10.821, 10.822, 10.823, 10.824, 10.825, 10.826, 10.827, 10.828, 10.829, 10.830, 10.831, 10.832, 10.833, 10.834, 10.835, 10.836, 10.837, 10.838, 10.839, 10.840, 10.841, 10.842, 10.843, 10.844, 10.845, 10.846, 10.847, 10.848, 10.849, 10.850, 10.851, 10.852, 10.853, 10.854, 10.855, 10.856, 10.857, 10.858, 10.859, 10.860, 10.861, 10.862, 10.863, 10.864, 10.865, 10.866, 10.867, 10.868, 10.869, 10.870, 10.871, 10.872, 10.873, 10.874, 10.875, 10.876, 10.877, 10.878, 10.879, 10.880, 10.881, 10.882, 10.883, 10.884, 10.885, 10.886, 10.887, 10.888, 10.889, 10.890, 10.891, 10.892, 10.893, 10.894, 10.895, 10.896, 10.897, 10.898, 10.899, 10.900, 10.901, 10.902, 10.903, 10.904, 10.905, 10.906, 10.907, 10.908, 10.909, 10.910, 10.911, 10.912, 10.913, 10.914, 10.915, 10.916, 10.917, 10.918, 10.919, 10.920, 10.921, 10.922, 10.923, 10.924, 10.925, 10.926, 10.927, 10.928, 10.929, 10.930, 10.931, 10.932, 10.933, 10.934, 10.935, 10.936, 10.937, 10.938, 10.939, 10.940, 10.941, 10.942, 10.943, 10.944, 10.945, 10.946, 10.947, 10.948, 10.949, 10.950, 10.951, 10.952, 10.953, 10.954, 10.955, 10.956, 10.957, 10.958, 10.959, 10.960, 10.961, 10.962, 10.963, 10.964, 10.965, 10.966, 10.967, 10.968, 10.969, 10.970, 10.971, 10.972, 10.973, 10.974, 10.975, 10.976, 10.977, 10.978, 10.979, 10.980, 10.981, 10.982, 10.983, 10.984, 10.985, 10.986, 10.987, 10.988, 10.989, 10.990, 10.991, 10.992, 10.993, 10.994, 10.995, 10.996, 10.997, 10.998, 10.999, 11.000

Busbar trunking
is granted on acc
09.01-INC, 12 Nov
as been carried
Attestation does no
roduction with the s
nber 2013

10, 10.11, 10.101, 1
joint and straight l
DEKRA, the result
if the product, subr
of the manufacturer
A is not the respons

DEKRA Certification B.V.

if this certificate and adjo

V. Meander 1051, 6825

ager

102 ED Amhem, The Ne

+31 88 96 83100 www.dekra-certification.com company registration 09085396

400A ... 6300A COMPACT BUSBAR PRODUCT OVERVIEW (E-LINE KX)

1- Standards & Certification:

- Busbar system shall be designed and manufactured as per IEC 61439-6 standard, which requires below listed tests. Each busbar rating shall have a separate type test certificate from an independent internationally accredited laboratory including below tests:
 - 10.2- Strength of material and parts, 10.2.2- Resistance to corrosion, 10.2.3- Properties of insulating materials, 10.2.3.1- Verification of thermal stability of enclosures, 10.2.3.2- Verification of resistance of insulating materials to abnormal heat and fire due to internal electric effects, 10.2.6- Mechanical impact, 10.2.7- Marking, 10.2.101- Ability to withstand mechanical loads, 10.2.101.1- Test procedure for a straight busbar trunking unit, 10.2.101.2- Test procedure for a joint, 10.2.101.3- Resistance of the enclosure to crushing, 10.3- Degree of protection of assembly, 10.4- Clearances and creepage distances, 10.5- Protection against electric shock and integrity of protective circuits, 10.5.2- Effective earth continuity between the exposed conductive parts of the assembly and the protective circuit, 10.5.3- Short-circuit withstand strength of the protective circuit, 10.9- Dielectric properties, 10.9.2- Power-frequency withstand voltage, 10.9.3- Impulse withstand voltage, 10.10- Verification of temperature rise, 10.11- Short-circuit withstand strength, 10.101- Resistance to flame propagation, 10.102- Fire resistance in building penetrations, Annex BB Phase conductor characteristics, Annex CC Fault-loop zero-sequences impedances, Annex DD Fault-loop resistances and reactances.
- Busbar system shall have CE marking.
- The manufacturer of busbar system shall have ISO 9001 and ISO 14001 certification.
- Each product shall have a "Type Label" including coding system, which identifies the brand, type of the unit, number of conductors and electrical details. The same coding shall be on the related certificate and catalogue.

2- Electrical Characteristics

- Busbar systems nominal insulation voltage shall be 1000 V.
- As per ampere rates, minimum short circuit values shall be as given below;

For Aluminium Conductors;	400-500A :1 sec/rms 16kA, Peak 32kA	For Copper Conductors;	550-650A :1 sec/rms 24kA, Peak 50,4kA
	630A :1 sec/rms 25kA, Peak 52,5kA		800A :1 sec/rms 40kA, Peak 84kA
	800A :1 sec/rms 35kA, Peak 73,5kA		1000A :1 sec/rms 50kA, Peak 105kA
	1000A :1 sec/rms 50kA, Peak 105kA		1250-1350A :1 sec/rms 60kA, Peak 132kA
	1250-1350A :1 sec/rms 60kA, Peak 132kA		1600-2000A :1 sec/rms 80kA, Peak 176kA
	1600-2500A :1 sec/rms 80kA, Peak 176kA		2500A :1 sec/rms 100kA, Peak 220kA
	2500-3150A :1 sec/rms 100kA, Peak 220kA		3300A and above :1 sec/rms 120kA, Peak 264kA
	3200A and above :1 sec/rms 120kA, Peak 264kA		

2.1- Housing

- Busbar system shall have "Sandwich-Compact" structure. Conductors shall be packed and placed into the housing without leaving air gap in order to provide low reactance.
- Housing shall be made of thermal processed, extruded aluminium, RAL7038-Electrostatic painted.
- Compact structure of the housing shall be provided by M6 screws applied at every 19cm along the entire length.
- The sandwich-compact structure shall continue at the plug-in points too. There shall not be air gap between conductors at the plug-in points.

2.2- Conductors

- Aluminium or Copper conductors shall be epoxy coated and tin plated at the joints upon the wire configuration and required numbers, which are described below.
- Compact busbar system shall have aluminium conductors between 400A – 5000A.
- Compact busbar system shall have copper conductors between 550A – 6300A.
- Compact busbar system shall have the following number of conductors and wire configuration;
 - a) 4 Conductors: (4 full size conductors + PE (housing)).
 - b) 4 ½ Conductors: (4 full size conductors + PE (50% earth conductor + housing)),
 - c) 5 Conductors: (5 full size conductors + PE (100% earth conductor + housing)).
- Phase conductors and neutral conductor shall have the same cross-section and they shall be insulated.
- Aluminium conductors shall be of EC grade aluminium. Minimum conductivity shall be 34m/mm².W.
- Copper conductors shall be minimum 99,95% electrolytic copper. Minimum conductivity shall be 56m/mm².W.

2.3- Insulation

- Insulation system shall be suitable for 1.000V continuous operation. Conductors shall be minimum thermo-set epoxy coated. Conductor size shall be designed so that temperature rise on the conductors shall not exceed 100C degree at nominal current, which helps to global heating problem. With this reason, insulation class shall be "B class".

2.4- Joint Structure

- Electrical and mechanical connection shall be made by placing conductor joints into the joint blocks of the connected conductors and followed by tightening and fastening of the joint bolts.

2.5- Protection

- Protection degree of the housing and joints shall be IP55/IP65 and IP67.

2.6- Accessories

- Busbar system shall have all necessary accessories (elbows, offsets, panel-transformer connections, reductions, etc.) Manufacturer shall supply special dimensioned units in short time, if the project conditions requires.
- For horizontal runs, a horizontal expansion unit shall be used at every 40m and expansion points of the building.
- For vertical applications, a vertical expansion unit shall be used at every floor. Busbar system shall be rigidly fixed by supports at every floor.

3- Tap Off Boxes

- Both, Feeder and Plug-in busbar systems shall be suitable for bolt-on type tap off box connections at the joints up to 1.000A.
- Bolt-on tap off boxes shall be installed to the joints without changing or adding any piece. Bolt-on tap off boxes shall be able to be moved between different rated busbars.
- Plug-in busbars shall have minimum 2 plug-in points on each 300cm length. Plug-in tap off box sizes shall be up to 630A. Unused plug-in points shall have covers, which can provide IP55 protection degree.
- Plug-in tap off boxes shall be suitable to install or removed from busbars without switching off the power on the busbar.
- Contacts of plug-in tap off box shall be plated by silver.
- Tap off boxes shall be manufactured of sheet steel and epoxy painted RAL3020 colour.
- Plug-in tap off boxes shall have electromechanical safety interlock system. Which means;
 - a-) Electromechanical interlock mechanism shall ensure that the tap off box cannot be removed mechanically from the busbar, when the switch is at "ON" position.
 - b-) Electromechanical interlock mechanism shall ensure that, cover of the box can be opened only, when the switch is at "OFF" position.
 - c-) When the cover is opened, inside protection degree shall be minimum IP2X against accessing to live conductors.
 - d-) While inserting the contacts of plug-in tap off box, earth contact shall make the first touch. While removing, it shall be disconnected last.
- Tap off boxes shall be suitable for any brand of MCCBs. Electromechanical interlock mechanism shall be suitable for all these MCCBs too.

4- Installation and Commissioning

- Busbar systems shall be installed as per Single-Line drawings respect to required ampere rates and manufacturer installation guide (torque values, lockers, etc.). Electrical installer shall run an insulation test after installation according to manufacturers test procedures. The results of the test shall be reported to the manufacturer. Minimum insulation value shall be 1 Mohm.

Item	Component List	Quantity

Company :
Project :
Project No :

Prepared by
Name :
Date :
Signature :



Please duplicate this page for your own use.

Component List	Quantity	Component	Item	Company : Project : Project No :	Name : Date : Signature :
				Prepared by	

Please duplicate this page for your own use.

EAE Elektrik A.S.
Akcaburgaz Mahallesi,
3114. Sokak, No:10 34522
Esenyurt - Istanbul
Tel: +90 (212) 866 20 00
Fax: +90 (212) 886 24 20

Please visit our website for the updated version of our catalogues.
www.eae.com.tr/EN



Catalogue 12-Eng. / Rev 12 2000 pcs. 20/12/2018
A.C.E.

EAE has full right to make any revisions or changes on this catalogue without any prior notice.

